

 MORRISON BROS. CO.

VENTING GUIDE

for aboveground storage tanks

*A Guide Used to Assist in
Equipment Selection for
Aboveground Storage Tanks*



This guide is intended for reference use only. All final details of design and construction shall meet the requirements of federal, state, and local codes. In cases where plan approval is required, such approval shall be obtained from the authority having jurisdiction before any work is performed. The equipment presented in the Guide applies only to shop fabricated tanks.



Contents

	Page
I. Background Information	ii
References	ii
Definitions	1
II. Example Calculations for Vent Selection	
Horizontal Cylindrical Storage Tank	2
Vertical Cylindrical Storage Tank	3
Horizontal Rectangular Storage Tank	4
Venting Exceptions: Special Purpose Tanks	5
Vent Combination Examples	6
III. Calculation Tables	
Pre-calculated Horizontal Cylindrical Storage Tanks	7-8
Pre-calculated Vertical Cylindrical Storage Tanks	9
Pre-calculated Horizontal Rectangular Storage Tanks	10
Wetted Areas for Horizontal Cylindrical Storage Tanks	11
Wetted Areas for Vertical Cylindrical Storage Tanks	12
Emergency Venting Capacity	13
Gallon Capacity per Foot of Length (or Height)	14
Vent Capacity	15-16
IV. Vent Selection	
Morrison Venting Equipment	18-29
V. Aboveground Fuel Storage Diagrams	
Pressure Systems	29-30
Suction Systems	31-32
Generator	33
Bulk Storage	34



Background Information

The Morrison Bros. Co. Venting Guide was created to assist in the selection of venting equipment for aboveground storage tanks. Examples on the next two pages illustrate a vent selection process. It is best to work through the examples before attempting to use any of the tables in this book.

Tables include examples for standard sized tanks. The venting capacity charts and wetted area tables were taken directly from NFPA 30 and UL 142.

The vent selection chapter includes venting capacities of specific Morrison vents. This data was obtained from results of laboratory testing and engineering calculations. Catalog pages of the Morrison equipment follow the vent capacity chart.

References

- NFPA 20** “Standard for the Installation of Stationary Pumps for Fire Protection” 2019 Edition. National Fire Protection Association, 1 Batterymarch Park, Quincy, MA 02269
- NFPA 30** “Flammable and Combustible Liquids Code” 2018 Edition. National Fire Protection Association, 1 Batterymarch Park, Quincy, MA 02269
- UL 142** “Steel Aboveground Tanks” 10th Edition. May 17, 2019. UL Standards for Safety—UL Publication Stock, 333 Pfingsten Road, Northbrook, IL 60062. Tel (847) 272-8800
- UL 142A** “Special Purpose Aboveground Tanks for Specific Flammable or Combustible Liquids” 1st Edition. May 17, 2019. UL Standards for Safety – UL Publication Stock, 333 Pfingston Road, Northbrook, IL 60062. Tel (847) 272-8800
- ULC S601-07** Standard for Shop Fabricated Steel Aboveground Tanks for Flammable and Combustible Liquids. December 2007. Underwriters’ Laboratories of Canada 7 Underwriters Rd., Toronto, ON M1R 3B4. Tel (514) 757-3611
- PEI RP200** “Recommended Practices for Installation of Aboveground Storage Systems for Motor Vehicle Fueling.” Petroleum Equipment Institute, 2008 Edition. P.O. Box 2380. Tulsa, OK, 74101; Tel (918) 494-9696
- OSHA 1910.106** Occupational Safety and Health Standards. March 1, 2016. Occupational Safety and Health Administration, 200 Constitution Ave., NW, Washington, DC 20210. Tel (800) 321-6742
- API 2000** Venting Atmospheric and Low-Pressure Storage Tanks. 1998. API, 1220 L Street, NW, Washington, DC 20005-4070. Tel (202) 682-8000
- Morrison Bros. Co.** 570 East 7th Street, Dubuque, Iowa 52001. Tel (563) 583-5701



Definitions

Emergency Venting — Venting sufficient to relieve excessive internal pressure in storage tanks caused by exposure fires. Venting rate may exceed requirements of normal atmospheric and product transfer effects. In such cases, the construction of the tank will determine if additional venting capacity must be provided.

Atmospheric Tank — A storage tank that has been designed to operate at pressures from atmospheric through a gauge pressure of 1.0 psi (6.9 kPa) (i.e., 760 mm Hg through 812 mm Hg) measured at the top of the tank.

Normal Vent — An opening, construction method, or device that allows the relief of excessive internal pressure or vacuum during normal storage and operations.

Pressure Relieving Devices — Defined in NFPA 30 section 22.7.3.1, where entire dependence for emergency relief is placed upon pressure relieving devices, the total venting capacity of both normal and emergency vents shall be enough to prevent rupture of the shell or bottom of the tank if vertical, or of the shell or heads if horizontal.

Wetted Area — Exposed surface or shell area of a tank used in determining the venting requirements needed for that size tank in event of an exposure fire. In a horizontal tank, the wetted area is calculated as 75% of the exposed surface area. In a vertical tank, the wetted area is calculated as the first 30 ft. above grade of the exposed shell area of the tank. In a rectangular tank, the wetted area is calculated as the total surface area of the tank bottom and the four sides, excluding the tank top.

SCFH — Abbreviation for Standard Cubic Feet per Hour used to quantify or measure the airflow and degree of pressure relief for venting calculations.

Vent Capacity — The maximum rate of airflow (SCFH) recorded under test conditions at a maximum pressure of 2.5 PSI for specific sized emergency vents. This capacity rating is often required to be indicated on the vent itself.



Vent Selection/Capacity Example 1

HORIZONTAL CYLINDRICAL STORAGE TANK

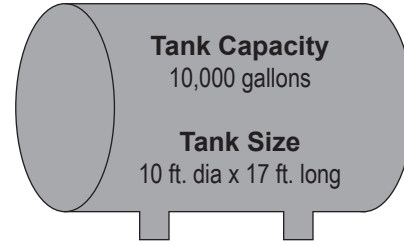

STEP 1 Pre-calculated Data for Common Sizes

Find tank size on Table B which can be found on page 7-8. Table lists wetted area and SCFH for common sized horizontal tanks. For a 10' x 17' tank – wetted area = 518 sq. ft. and required vent capacity = 360,840 SCFH. Proceed to Step 5.

STEP 2 Wetted Area Table

If tank size is NOT listed on Table B, page 7, wetted area can also be found on Table E, page 11. Follow grid for this example – 10' diameter x 17' length = 518 sq. ft. Proceed to Step 4.

STEP 3 Calculate Wetted Area

If the tank size is NOT on either chart, wetted area can be calculated. For Horizontal Tanks, wetted area = 75% of the total exposed surface area.

For a 10' x 17' tank—

$$0.75[2(\text{area of each end}) + (\text{area of shell})] = \text{wetted area}$$

$$\pi = 3.1416, d = \text{diameter}, L = \text{length}, WA = \text{wetted area}$$

$$WA = 0.75[(\pi d^2 \div 2) + (\pi dL)]$$

$$0.75[((3.1416)(10^2) \div 2) + (3.1416)(10)(17)]$$

$$WA = 518 \text{ sq. ft.}$$

STEP 4 Determine SCFH Requirement

Use Table F: Venting Capacity Chart on page 13. Wetted area must be known (518 sq. ft.). Since 518 is between 500 and 600 on the chart, interpolation is needed and is done as follows:

	600 sq. ft.	392,000	SCFH
	<u>500 sq. ft.</u>	<u>354,000</u>	SCFH
Difference =	100 sq. ft.	38,000	SCFH

$$\frac{38,000}{100} = \frac{x}{(518-500)} \quad x = 6,840 \text{ SCFH}$$

$$\text{Total SCFH Required: } (6,840 + 354,000) = 360,840 \text{ SCFH}$$

STEP 5 Vent Selection

Options based on size of piping, type of product, flow requirements, required venting capacity and mounting. For the sake of this example, use 2" piping, Class 1B liquid. The normal vent size should be no smaller than the system piping, so a Morrison 2" Fig. 748A (20,000 SCFH) is selected.

Total required venting capacity for this tank example was determined to be 360,840 SCFH. Normal venting and emergency venting may be combined to reach this total. Morrison Vent Capacities are listed on Table I, page 15. Since the 6" Emergency Vent (299,684 SCFH) can not provide enough additional capacity to meet the requirement, an 8" Emergency Vent (503,517 SCFH) is selected. In specifying pressure settings, it is recommended that the Emergency Vent NOT be less than the normal vent. Therefore, the vent specification for this example is as follows:

Normal Vent - 2" Fig 748A	20,000	SCFH
(8 oz pressure - 1 oz vacuum)		
Emergency Vent - 8" Fig 244O	<u>503,517</u>	SCFH
(16 oz pressure)		
Total Venting Provided	523,517	SCFH

STEP 6 Verification

Refer to Table A on page 6 showing vent combinations and verify the total SCFH figure. Also refer to the product illustrations on pages 17-26 and verify the selection for correct option on material compatibility and mounting requirements.



Vent Selection/Capacity Example 2

VERTICAL CYLINDRICAL STORAGE TANK

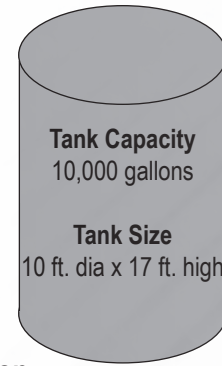

STEP 1 Pre-calculated Data for Common Sizes

Find tank size on Table C which can be found on page 9. Table lists wetted area and SCFH for common sized vertical tanks. For a 10' x 17' tank – wetted area = 613 sq. ft. and required vent capacity = 396,680 SCFH. Proceed to Step 5.

STEP 2 Wetted Area Table

If tank size is NOT listed on Table C, page 9, wetted area can also be found on Table F, page 12. Follow grid for this example – 10' diameter x 17' height = 613 sq. ft. Proceed to Step 4.

STEP 3 Calculate Wetted Area

If the tank size is NOT on either chart, wetted area can be calculated. For Vertical Tanks, wetted area = exposed shell area excluding the top surface to elevation not more than 30 ft. above the bottom.

For a 10' x 17' tank:

Wetted Area = (area of shell) + (area of bottom surface)

$\pi = 3.1416$, d = diameter, L = length, WA = wetted area

$$WA = (\pi d)L + \pi(\frac{1}{2}d)^2$$

$$(3.1416)(10)(17) + (3.1416)(5^2)$$

$$WA = 613 \text{ sq. ft.}$$

STEP 4 Determine SCFH Requirement

Use Table G: Venting Capacity Chart on page 13. Wetted area must be known (613 sq. ft.). Since 613 is between 600 and 700 on the chart, interpolation is needed and is done as follows:

	700 sq. ft.	428,000	SCFH
	<u>600 sq. ft.</u>	<u>392,000</u>	SCFH
Difference =	100 sq. ft.	36,000	SCFH

$$\frac{36,000}{100} = \frac{x}{(613-600)} \quad x = 4,680 \text{ SCFH}$$

Total SCFH Required: (4,380 + 392,000) = 396,680 SCFH

STEP 5 Vent Selection

Options based on size of piping, type of product, flow requirements, required venting capacity and mounting. For the sake of this example, use 2" piping, Class 1B liquid. The normal vent size should be no smaller than the system piping, so a Morrison 2" Fig. 748A (20,000 SCFH) is selected.

Total required venting capacity for this tank example was determined to be 396,680 SCFH. Normal venting and emergency venting may be combined to reach this total. Morrison Vent Capacities are listed on Table I, page 15. Since the 6" Emergency Vent (299,684 SCFH) can not provide enough additional capacity to meet the requirement, an 8" Emergency Vent (503,517 SCFH) is selected. In specifying pressure settings, it is recommended that the Emergency Vent NOT be less than the normal vent. Therefore, the vent specification for this example is as follows:

Normal Vent - 2" Fig 748A	20,000	SCFH
(8 oz pressure - 1 oz vacuum)		
Emergency Vent - 8" Fig 244O	<u>503,517</u>	SCFH
(16 oz pressure)		
Total Venting Provided	523,517	SCFH

STEP 6 Verification

Refer to Table A on page 6 showing vent combinations and verify the total SCFH figure. Also refer to the product illustrations on pages 17-26 and verify the selection for correct option on material compatibility and mounting requirements.



Vent Selection/Capacity Example 3

HORIZONTAL RECTANGULAR STORAGE TANK

Tank Capacity
10,000 gallons

Tank Size
274”L x 130”W x 65”H
(22’-10”L x 10’-10”W x 5’5”H)

STEP 1 Pre-calculated Data for Common Sizes

Find tank size on Table D which can be found on page 10. Table lists wetted area and SCFH for common sized tanks. For a 274”L x 130”W x 65”H (22’-10”L x 10’-10”W x 5’5”H) tank – wetted area = 612 sq. ft. and required vent capacity = 396,320 SCFH. Proceed to Step 4.

STEP 2 Wetted Area Table

If tank size is NOT listed on Table D, page 10, wetted area can be calculated. For Horizontal Rectangular Tanks, wetted area = exposed shell area excluding the top surface of the tank.

For a 274”L x 130”W x 65”H tank:

$$\text{Wetted area} = \frac{(L \times W) + 2(L \times H) + 2(W \times H)}{144}$$

L = length, W = width, H = height

$$\frac{(274 \times 130) + 2(274 \times 65) + 2(130 \times 65)}{144}$$

Wetted Area = 612 Sq. ft.

STEP 3 Determine SCFH Requirement

Use Table G: Venting Capacity Chart on page 13. Wetted area must be known (612 sq. ft.). Since 612 is between 600 and 700 on the chart, interpolation is needed and is done as follows:

	700 sq. ft.	428,000	SCFH
	<u>600 sq. ft.</u>	<u>392,000</u>	SCFH
Difference =	100 sq. ft.	36,000	SCFH
	36,000	=	$\frac{x}{(612-600)}$
	100		x = 4,320 SCFH

Total SCFH Required: (4,320 + 392,000) = 396,320 SCFH

STEP 4 Vent Selection

Options based on size of piping, type of product, flow requirements, required venting capacity and mounting. For the sake of this example, use 2” piping, Class 1B liquid. The normal vent size should be no smaller than the system piping, so a Morrison 2” Fig. 748A (20,000 SCFH) is selected.

Total required venting capacity for this tank example was determined to be 396,320 SCFH. Normal venting and emergency venting may be combined to reach this total. Morrison Vent Capacities are listed on Table I, page 15. Since the 6” Emergency Vent (299,684 SCFH) can not provide enough additional capacity to meet the requirement, an 8” Emergency Vent (503,517 SCFH) is selected. In specifying pressure settings, it is recommended that the Emergency Vent NOT be less than the normal vent. Therefore, the vent specification for this example is as follows:

Normal Vent - 2” Fig 748A (8 oz pressure - 1 oz vacuum)	20,000	SCFH
Emergency Vent - 8” Fig 2440 (16 oz pressure)	<u>503,517</u>	SCFH
Total Venting Provided	523,517	SCFH

STEP 5 Verification

Refer to Table A on page 6 showing vent combinations and verify the total SCFH figure. Also refer to the product illustrations on pages 17-26 and verify the selection for correct option on material compatibility and mounting requirements.



Venting Exceptions: Special Purpose Tanks

The following tanks classified in UL 142A:

- Work Top Tanks— for Class III Fuels and Oils.
- Lube Oil Tanks— for Class IIIB Oils.
- Used Oil Tanks— for Class IIIB Oils.

The emergency vent opening nominal size and the venting capacity may be lower than required by UL 142, Section 8, Table 8.1. These types of tanks may qualify for a reduction in venting requirements per the following chart:

Tank Size	Percent emergency venting reduction
Tanks ≤ 330 gallons	up to 20 percent
Tanks ≤ 660 gallons	up to 15 percent
Tanks ≤ 1250 gallons	up to 10 percent
Tanks ≤ 5000 gallons	up to 5 percent

Source: ANSI/UL 142A Section 5, First Edition, May 17, 2019.



Table A: Vent Combination Examples

Model 244 Emergency Vents used for venting capacities.

MORRISON VENTS		SCFH
2"	Fig. 748A - 4 oz P	20,000
4"	Fig. 244O - 8 oz P	131,700
TOTAL SCFH:		151,700
2"	Fig. 748A - 8 oz P	20,000
6"	Fig. 244O - 16 oz P	299,684
TOTAL SCFH:		319,684
2"	Fig. 748A - 8 oz P	20,000
8"	Fig. 244O - 16 oz P	503,517
TOTAL SCFH:		523,517
2"	Fig. 748A - 8 oz P	20,000
10"	Fig. 244OF - 16 oz P	890,275
TOTAL SCFH:		910,275
2"	Fig. 948A - 2.5-6"wc P	36,720
10"	Fig. 244OF - 8 oz P	890,275
TOTAL SCFH:		926,995
3"	Fig. 748A - 8 oz P	43,000
10"	Fig. 244OF - 10 oz P	890,275
TOTAL SCFH:		933,275
2"	Fig. 749 - 8 oz P	8,500
4"	Fig. 244O - 16 oz P	131,700
TOTAL SCFH:		140,200
3"	Fig. 748A - 8 oz P	43,000
6"	Fig. 244O - 16 oz P	299,684
TOTAL SCFH:		342,684
3"	Fig. 748A - 8 oz P	43,000
8"	Fig. 244O - 16 oz P	503,517
TOTAL SCFH:		546,517
3"	Fig. 922 - 8 oz P	30,300
10"	Fig. 244OF - 16 oz P	890,275
TOTAL SCFH:		920,575
3"	Fig. 748A - 8 oz P	43,000
10"	Fig. 244OF - 8 oz P	890,275
TOTAL SCFH:		933,275
4"	Fig. 354	116,900
10"	Fig. 244OF - 8 oz P	890,275
TOTAL SCFH:		1,007,175

Model 245 Lightweight Emergency Vents used for venting capacities.

MORRISON VENTS		SCFH
2"	Fig. 748A - 4 oz P	20,000
4"	Fig. 245 - 8 oz P	129,369
TOTAL SCFH:		149,369
2"	Fig. 748A - 8 oz P	20,000
6"	Fig. 245 - 8 oz P	331,750
TOTAL SCFH:		351,750
2"	Fig. 748A - 8 oz P	20,000
8"	Fig. 245 - 8 oz P	527,441
TOTAL SCFH:		547,441
2"	Fig. 748A - 8 oz P	20,000
10"	Fig. 245F - 8 oz P	972,110
TOTAL SCFH:		992,100
2"	Fig. 948A - 2.5-6"wc P	36,720
10"	Fig. 245F - 8 oz P	972,110
TOTAL SCFH:		1,008,830
3"	Fig. 748A - 8 oz P	43,000
10"	Fig. 245F - 8 oz P	972,110
TOTAL SCFH:		1,015,110
2"	Fig. 749 - 8 oz P	8,500
4"	Fig. 245 - 8 oz P	129,369
TOTAL SCFH:		137,869
3"	Fig. 748A - 8 oz P	43,000
6"	Fig. 245 - 8 oz P	331,750
TOTAL SCFH:		374,750
3"	Fig. 748A - 8 oz P	43,000
8"	Fig. 245 - 8 oz P	527,441
TOTAL SCFH:		570,441
3"	Fig. 922 - 8 oz P	30,300
10"	Fig. 245F - 8 oz P	972,110
TOTAL SCFH:		1,002,410
3"	Fig. 748A - 8 oz P	43,000
10"	Fig. 245F - 8 oz P	972,110
TOTAL SCFH:		1,015,110
4"	Fig. 354	116,900
10"	Fig. 245F - 8 oz P	972,110
TOTAL SCFH:		1,089,010

Note: All calculations are less screens.

**Table B: Pre-Calculated Data****HORIZONTAL CYLINDRICAL STORAGE TANKS**

TANK			WETTED AREA (Sq Ft)	REQ'D VENT CAPACITY (SCFH)	MORRISON EMERGENCY VENT SIZE WITHOUT SCREEN (Inches)	MORRISON EMERGENCY VENT SIZE WITH SCREEN (Inches)
CAPACITY (Gallons)	DIAMETER (Ft or In)	LENGTH (Ft-In)				
280	36"	5'-2"	47	49,520	3	3
300	38"	5'-0"	49	51,640	3	4
500	48"	5'-5"	69	72,650	4	4
530	46"	6'-0"	71	74,750	4	4
550	48"	6'-0"	75	78,950	4	4
1,000	48"	10'-8"	119	124,950	4	5
1,000	64"	6'-0"	109	114,450	4	4
1,500	64"	9'-0"	147	154,350	5	5
2,000	64"	12'-0"	184	193,200	6	6
2,500	64"	15'-0"	222	223,320	6	6
3,000	64"	18'-0"	259	243,680	6	6
3,000	6'-0"	14'-0"	240	233,400	6	6
4,000	64"	24'-0"	335	281,100	6	N/A
4,000	6'-0"	19'-0"	311	270,060	6	N/A
5,000	8'-0"	13'-4"	326	276,960	6	N/A
6,000	8'-0"	16'-0"	376	300,480	8	N/A
8,000	8'-0"	21'-4"	477	344,340	8	N/A
10,000	8'-0"	27'-0"	584	385,920	8	N/A
10,000	9'-0"	21'-0"	540	369,200	8	N/A
10,000	10'-0"	17'-0"	518	360,840	8	N/A
10,000	10'-6"	15'-7"	515	359,700	8	N/A
12,000	8'-0"	32'-0"	678	420,080	8	N/A
12,000	9'-0"	25'-0"	625	401,000	8	N/A
12,000	10'-0"	20'-6"	600	392,000	8	N/A
12,000	11'-0"	17'-0"	583	385,540	8	N/A
15,000	8'-0"	40'-0"	829	470,990	8	N/A
15,000	10'-6"	23'-5"	703	429,020	8	N/A
20,000	10'-0"	34'-2"	922	499,820	8	N/A
20,000	10'-6"	31'-0"	896	491,760	8	N/A
20,000	11'-0"	28'-0"	868	483,080	8	N/A
25,000	10'-6"	38'-6"	1,082	537,530	10	N/A

(TABLE CONTINUED ON PAGE 8)

Table B: Pre-Calculated Data (continued from page 7)

HORIZONTAL CYLINDRICAL STORAGE TANKS

TANK			WETTED AREA (Sq Ft)	REQ'D VENT CAPACITY (SCFH)	MORRISON EMERGENCY VENT SIZE WITHOUT SCREEN (Inches)	MORRISON EMERGENCY VENT SIZE WITH SCREEN (Inches)
CAPACITY (Gallons)	DIAMETER (Ft or In)	LENGTH (Ft-In)				
30,000	10'-0"	51'-2"	1,324	575,600	10	N/A
30,000	10'-6"	46'-3"	1,274	568,100	10	N/A
40,000	12'-0"	47'-6"	1,512	602,120	10	N/A
50,000	12'-0"	59'-6"	1,852	664,980	10	N/A
50,000	12'-6"	54'-6"	1,789	637,735	10	N/A
60,000	12'-0"	71'-0"	2,177	680,585	10	N/A
60,000	12'-6"	65'-5"	2,110	637,550	10	N/A
60,000	13'-0"	60'-6"	2,052	667,460	10	N/A
70,000	13'-0"	72'-0"	2,404	704,380	10	N/A

**Table C: Pre-Calculated Data**

VERTICAL CYLINDRICAL STORAGE TANKS

TANK			WETTED AREA (Sq Ft)	REQ'D VENT CAPACITY (SCFH)	MORRISON EMERGENCY VENT SIZE WITHOUT SCREEN (Inches)	MORRISON EMERGENCY VENT SIZE WITH SCREEN (Inches)
TANK CAPACITY (Gallons)	DIAMETER (Ft or In)	LENGTH (Ft-In)				
280	36"	5'-2"	56	58,751	3"	4"
300	38"	5'-0"	58	60,706	3"	4"
500	48"	5'-5"	81	84,872	4"	4"
530	46"	6'-0"	84	88,225	4"	4"
550	48"	6'-0"	88	92,642	4"	4"
1,000	48"	10'-8"	147	153,938	5"	5"
1,000	64"	6'-0"	123	129,015	4"	5"
1,500	64"	9'-0"	173	182,450	5"	6"
2,000	64"	12'-0"	223	224,105	6"	6"
2,500	64"	15'-0"	274	251,307	6"	N/A
3,000	6'-0"	14'-0"	292	260,927	6"	N/A
3,000	64"	18'-0"	324	276,009	6"	N/A
4,000	64"	24'-0"	424	322,275	8"	N/A
4,000	6'-0"	19'-0"	386	305,479	8"	N/A
5,000	8'-0"	13'-4"	385	304,977	8"	N/A
6,000	8'-0"	16'-0"	452	334,003	8"	N/A
8,000	8'-0"	21'-4"	586	386,843	8"	N/A
10,000	8'-0"	27'-0"	729	437,809	8"	N/A
10,000	9'-0"	21'-0"	657	412,656	8"	N/A
10,000	10'-0"	17'-0"	613	396,540	8"	N/A
10,000	10'-6"	15'-7"	601	392,228	8"	N/A
12,000	8'-0"	32'-0"	804	463,317	8"	N/A
12,000	9'-0"	25'-0"	770	451,961	8"	N/A
12,000	10'-0"	20'-6"	723	435,672	8"	N/A
12,000	11'-0"	17'-0"	683	421,704	8"	N/A
15,000	8'-0"	40'-0"	804	463,317	8"	N/A
15,000	10'-6"	23'-5"	859	480,299	8"	N/A
20,000	10'-0"	34'-2"	1,021	527,468	10"	N/A
20,000	10'-6"	31'-0"	1,076	536,572	10"	N/A
20,000	11'-0"	28'-0"	1,063	534,336	10"	N/A
25,000	10'-6"	38'-6"	1,076	536,572	10"	N/A
30,000	10'-6"	46'-3"	1,076	536,572	10"	N/A
30,000	12'-0"	35'-6"	1,244	563,610	10"	N/A
30,000	12'-6"	32'-9"	1,301	572,122	10"	N/A
40,000	12'-0"	47'-6"	1,244	563,610	10"	N/A
40,000	12'-6"	43'-8"	1,301	572,122	10"	N/A
40,000	13'-0"	40'-4"	1,358	580,693	10"	N/A
49,500	13'-0"	50'-0"	1,358	580,693	10"	N/A
57,000	14'-0"	50'-0"	1,473	596,910	10"	N/A



Table D: Pre-Calculated Data

HORIZONTAL RECTANGULAR STORAGE TANKS

TANK				WETTED AREA (Sq Ft)	REQ'D VENT CAPACITY (SCFH)	MORRISON EMERGENCY VENT SIZE WITHOUT SCREEN (Inches)	MORRISON EMERGENCY VENT SIZE WITH SCREEN (Inches)
CAPACITY (Gallons)	LENGTH (Ft-In)	WIDTH (Ft-In)	HEIGHT (Ft-In)				
125	6'-8"	2'-9"	1'-0"	37	38,950	3	3
186	2'-8"	2'-8"	3'-6"	44	46,340	3	3
250	4'-4"	4'-0"	1'-11"	49	51,640	3	4
250	6'-8"	2'-9"	1'-11"	54	56,900	3	4
500	7'-6"	3'-0"	3'-0"	86	90,560	4	4
500	10'-0"	3'-6"	2'-0"	89	93,740	4	4
1,000	9'-8"	4'-8"	3'-0"	131	137,550	5	5
1,000	10'-0"	4'-7"	2'-11"	133	139,650	5	5
2,000	10'-2"	6'-11"	3'-10"	201	211,560	6	6
2,000	10'-8"	6'-4"	4'-0"	204	213,240	6	6
2,500	10'-2"	6'-11"	4'-9"	233	229,480	6	6
3,000	8'-6"	6'-10"	7'-2"	278	253,560	6	N/A
3,000	13'-9"	5'-5"	5'-5"	282	255,640	6	N/A
4,000	11'-4"	6'-10"	7'-2"	338	282,480	6	N/A
4,000	18'-2"	5'-5"	5'-5"	354	289,920	6	N/A
5,000	22'-9"	5'-5"	5'-5"	428	323,760	8	N/A
6,000	13'-8"	10'-10"	5'-5"	413	317,460	8	N/A
6,000	16'-5"	6'-10"	7'-2"	445	330,900	8	N/A
6,000	27'-4"	5'-5"	5'-5"	503	355,140	8	N/A
8,000	18'-2"	10'-10"	5'-5"	511	358,180	8	N/A
8,000	21'-11"	6'-10"	7'-2"	562	377,560	8	N/A
10,000	22'-10"	10'-10"	5'-5"	612	396,320	8	N/A
10,000	27'-5"	6'-10"	7'-2"	678	420,080	8	N/A
12,000	27'-4"	10'-10"	5'-5"	710	431,400	8	N/A
12,000	32'-11"	6'-10"	7'-2"	795	460,300	8	N/A



Table E: Approximate Wetted Areas

HORIZONTAL CYLINDRICAL STORAGE TANKS

Tank Diameter	3 Ft	4 Ft	5 Ft	6 Ft	7 Ft	8 Ft	9 Ft	10 Ft	11 Ft	12 Ft	13 Ft
Tank Length	<i>Approximate Wetter Area of Tanks With Flat Heads, Square Feet</i>										
3 Ft	32										
4 Ft	39	55									
5 Ft	46	65	88								
6 Ft	53	74	100	128							
7 Ft	60	84	112	142	173						
8 Ft	67	93	124	156	190	226					
9 Ft	74	102	136	170	206	245	286				
10 Ft	81	112	147	184	223	264	308	353			
11 Ft	88	121	159	198	239	283	329	377	428		
12 Ft	95	131	171	213	256	301	350	400	454	509	
13 Ft	102	140	183	227	272	320	371	424	480	537	598
14 Ft	109	150	194	241	289	339	393	447	506	565	628
15 Ft	116	159	206	255	305	358	414	471	532	594	659
16 Ft	123	169	218	269	322	377	435	495	558	622	690
17 Ft	130	178	230	283	338	395	456	518	584	650	720
18 Ft	137	188	242	298	355	414	477	542	610	678	751
19 Ft		197	253	312	371	433	499	565	636	707	781
20 Ft		206	265	326	388	452	520	589	662	735	812
21 Ft		216	277	340	404	471	541	612	688	763	843
22 Ft		225	289	354	421	490	562	636	714	792	873
23 Ft		235	300	368	437	508	584	659	740	820	904
24 Ft		244	312	383	454	527	605	683	765	848	935
25 Ft			324	397	470	546	626	706	791	876	965
26 Ft			336	411	487	565	647	730	817	905	996
27 Ft			347	425	503	584	668	754	843	933	1027
28 Ft			359	440	520	603	690	777	869	961	1057
29 Ft			371	454	536	621	711	801	895	989	1088
30 Ft			383	468	553	640	732	824	921	1018	1118
31 Ft			395	482	569	659	753	848	947	1046	1149
32 Ft				496	586	678	775	871	973	1074	1180
33 Ft				510	602	697	796	895	999	1103	1210
34 Ft				524	619	715	817	918	1025	1131	1241
35 Ft				539	635	734	838	942	1051	1159	1272
36 Ft				553	652	753	860	966	1077	1187	1302
37 Ft				567	668	772	881	989	1103	1216	1333

Tank Diameter	3 Ft	4 Ft	5 Ft	6 Ft	7 Ft	8 Ft	9 Ft	10 Ft	11 Ft	12 Ft	13 Ft
Tank Length	<i>Approximate Wetter Area of Tanks With Flat Heads, Square Feet</i>										
38 Ft					685	791	902	1013	1129	1244	1363
39 Ft					701	810	923	1036	1155	1272	1394
40 Ft					718	828	944	1060	1181	1301	1425
41 Ft					734	847	966	1083	1207	1329	1455
42 Ft					751	866	987	1107	1233	1357	1486
43 Ft					767	885	1008	1130	1259	1385	1517
44 Ft						904	1029	1154	1284	1414	1547
45 Ft						923	1051	1178	1310	1442	1578
46 Ft						941	1072	1201	1336	1470	1609
47 Ft						960	1093	1225	1362	1498	1639
48 Ft						979	1114	1248	1388	1527	1670
49 Ft							1135	1272	1414	1555	1700
50 Ft							1157	1295	1440	1583	1731
51 Ft							1178	1319	1466	1612	1762
52 Ft							1199	1342	1492	1640	1792
53 Ft							1220	1366	1518	1668	1823
54 Ft							1246	1389	1544	1697	1854
55 Ft							1263	1413	1570	1725	1884
56 Ft								1437	1593	1753	1915
57 Ft								1460	1622	1781	1945
58 Ft								1484	1648	1809	1976
59 Ft								1507	1674	1839	2007
60 Ft								1531	1700	1867	2037
61 Ft									1726	1895	2068
62 Ft									1752	1923	2099
63 Ft									1778	1951	2129
64 Ft									1803	1980	2160
65 Ft									1829	2007	2190
66 Ft									1855	2036	2221
67 Ft										2064	2252
68 Ft										2093	2282
69 Ft										2121	2313
70 Ft										2149	2343
71 Ft										2177	2374
72 Ft										2205	2405

SI Units: 1 Ft = 0.30 m; 1 sq ft = 0.09 sq m
 Source for Chart: UL 142, Table A-2, 10th Edition, May 17, 2019.



Table F: Approximate Wetted Areas

VERTICAL CYLINDRICAL STORAGE TANKS

(Area of Shell to Elevation Not More Than 30 Ft. Above Bottom)

Tank Diameter	3 Ft	4 Ft	5 Ft	6 Ft	7 Ft	8 Ft	9 Ft	10 Ft	11 Ft	12 Ft	13 Ft	14 Ft
Tank Length	<i>Wetted Area, Square Feet</i>											
3 Ft	35											
4 Ft	45	63										
5 Ft	54	75	98									
6 Ft	64	88	114	141								
7 Ft	73	101	130	160	192							
8 Ft	82	113	145	179	214	251						
9 Ft	92	126	161	198	236	276	318					
10 Ft	101	138	177	217	258	302	346	393				
11 Ft	111	151	192	236	280	327	375	424	475			
12 Ft	120	163	208	254	302	352	403	456	510	565		
13 Ft		176	224	273	324	377	431	487	544	603	664	
14 Ft		188	240	292	346	402	459	518	579	641	705	770
15 Ft		201	255	311	368	427	488	550	613	679	745	814
16 Ft		214	271	330	390	452	516	581	648	716	786	858
17 Ft			287	349	412	478	544	613	683	754	827	902
18 Ft			302	368	434	503	573	644	717	792	868	946
19 Ft			318	386	456	528	601	675	752	829	909	990
20 Ft			334	405	478	553	629	707	786	867	950	1034
21 Ft				424	500	578	657	738	821	905	990	1078
22 Ft				443	522	603	686	770	855	942	1031	1122
23 Ft				462	544	628	714	801	890	980	1072	1166
24 Ft				481	566	653	742	833	924	1018	1113	1210
25 Ft					588	679	770	864	959	1056	1154	1253
26 Ft					610	704	799	895	994	1093	1195	1297
27 Ft					632	729	827	927	1028	1131	1235	1341
28 Ft					654	754	855	958	1063	1169	1276	1385
29 Ft						779	884	990	1097	1206	1317	1429
30 Ft						804	912	1021	1132	1244	1358	1473

SI Units: 1 Ft = 0.30 m; 1 sq ft = 0.09 sq m

Source for Chart: UL 142, Table A-3, 9th Edition, May 17, 2019.

**Table G: Emergency Venting Capacity**

Wetted surface, square feet ^a	Venting capacity, standard cubic feet per hour ^b
20	21,100
30	31,600
40	42,100
50	52,700
60	63,200
70	73,700
80	84,200
90	94,800
100	105,000
120	126,000
140	147,000
160	168,000
180	190,000
200	211,000
250	239,000
300	265,000
350	288,000
400	312,000
500	354,000
600	392,000
700	428,000
800	462,000
900	493,000
1000	524,000
1200	557,000
1400	587,000
1600	614,000
1800	639,000
2000	662,000
2400	704,000
2800	742,000

^a Interpolate for intermediate values.

^b These values taken from NFPA 30–2018, Table 22.7.3.2 and UL 142-10. PDF Table 8.1 page 23.

Notes:

- Emergency venting capacity is based on atmospheric pressure of 14.7 psia and 60° F (101.4 kPa and 16° C).
- If tank is to be equipped with a venting device or flame arrestor, the vent opening is to accommodate the venting device or flame arrestor in accordance with the listed SCFH.

Normal Venting Recommendations

NFPA 30 — 2018

21.4.3.3 Normal vents shall be sized in accordance with either API Standard 2000, Venting Atmospheric and Low-Pressure Storage Tanks, or another approved standard. Alternatively, the normal vent shall be at least as large as the largest filling or withdrawal connection, but in no case shall it be less than 1¼ in. (3.2 cm) nominal inside diameter.



Table H: Gallon Capacity Per Foot of Length (or Height)

Diameter (Inches)	U.S. Gallons Per Ft Length	Diameter (Inches)	U.S. Gallons Per Ft Length	Diameter (Inches)	U.S. Gallons Per Ft Length
24	23.50	65	172.38	106	458.30
25	25.50	66	177.72	107	467.70
26	27.58	67	183.15	108	475.89
27	29.74	68	188.66	109	485.00
28	31.99	69	194.25	110	493.70
29	34.31	70	199.92	111	502.70
30	36.72	71	205.67	112	511.90
31	39.21	72	211.51	113	521.40
32	41.78	73	217.42	114	530.24
33	44.43	74	223.42	115	540.00
34	47.16	75	229.50	116	549.50
35	49.98	76	235.66	117	558.51
36	52.88	77	241.90	118	568.00
37	55.86	78	248.23	119	577.80
38	58.92	79	254.63	120	587.52
39	62.06	80	261.12	121	597.70
40	65.28	81	267.69	122	607.27
41	68.58	82	274.34	123	617.26
42	71.97	83	281.07	124	627.00
43	75.44	84	287.88	125	638.20
44	78.99	85	294.78	126	647.74
45	82.62	86	301.76	127	658.60
46	86.33	87	308.81	128	668.47
47	90.13	88	315.95	129	678.95
48	94.00	89	323.18	130	690.30
49	97.96	90	330.48	131	700.17
50	102.00	91	337.86	132	710.90
51	106.12	92	345.33	133	721.71
52	110.32	93	352.88	134	732.60
53	114.61	94	360.51	135	743.58
54	118.97	95	368.22	136	754.64
55	123.42	96	376.01	137	765.78
56	127.95	97	383.89	138	776.99
57	132.56	98	391.84	139	788.30
58	137.25	99	399.88	140	799.68
59	142.02	100	408.00	141	811.14
60	146.88	101	416.00	142	822.69
61	151.82	102	424.48	143	834.32
62	156.83	103	433.10	144	846.03
63	161.93	104	441.80		
64	167.12	105	449.82		

**Table I: Vent Capacity**

Size	Item Number	Mounting Connection	Description	Pressure (oz/sq in.)	Capacity (SCFH)	Data Source
1½"	354	Female Slip On	Updraft Vent	0	27,650	Tested at Iowa State University by P. Kavanagh, 1990
2"	244OM	Male Threads	Emergency Vent	8	31,917	Colorado Engineering Experiment Station Inc., 2014
2"	244OMS	Male Threads	Emergency Vent w/ Screen	8	24,069	Colorado Engineering Experiment Station Inc., 2014
2"	245M	Male Threads	Emergency Vent	8	31,917	Colorado Engineering Experiment Station Inc., 2014
2"	245MS	Male Threads	Emergency Vent w/ Screen	8	24,069	Colorado Engineering Experiment Station Inc., 2014
2"	351S	Female Threads	Flame Arrester	0	22,000	Tested at Ohio State Univ. by O. E. Buxton Jr. 1967
2"	351S/748A	Female Threads	Flame Arrester/Vent	2, 4, 6, or 8	15,500	Based on ISU Test of 2" 351S/548-748 - 8 oz. by Kavanagh, 1990
2"	351S/748A	Female Threads	Flame Arrester/Vent	12 or 16	13,000	Based on ISU Test of 2" 351S/548-748 - 8 oz. by Kavanagh, 1990
2"	354	Female Slip On	Updraft Vent	0	27,650	Tested at Univ. Wisconsin Platteville by L. Lee, 1988
2"	748A	Female Threads	Pressure Vacuum Vent	2, 4, or 6	20,200	Based on ISU Test of 2" 548 - 8 oz. by Kavanagh, 1960
2"	748A	Female Threads	Pressure Vacuum Vent	8	20,000	Based on ISU Test of 2" 548 - 8 oz. by Kavanagh, 1960
2"	748A	Female Threads	Pressure Vacuum Vent	12	18,600	Based on ISU Test of 2" 548 - 8 oz. by Kavanagh, 1960
2"	748A	Female Threads	Pressure Vacuum Vent	16	18,600	Tested at Iowa State Univ. by P. Kavanagh, 1960
2"	749	Female Thds/Slip On	Pressure Vacuum Vent	8	8,500	Tested at Univ. of Wisconsin Platteville by L. Lee, 1988
2"	749	Female Thds/Slip On	Pressure Vacuum Vent	12	8,500	Tested at Univ. of Wisconsin Platteville by L. Lee, 1988
2"	749 CRB	Female Thds/Slip On	Pressure Vacuum Vent	1.70	11,000	Tested at Univ. of Wisconsin Platteville by L. Lee, 1996
2"	922	Female Threads	Pressure Vacuum Vent Alarm	6	30,120	Tested at Environ Laboratories, 2006
2"	922	Female Threads	Pressure Vacuum Vent Alarm	8	30,300	Tested at Environ Laboratories, 2006
2"	948A	Female Threads	Pressure Vacuum Vent Alarm	2.5-6" WC	36,720	Tested at Underwriters Laboratories, 2012
3"	244OM	Male Threads	Emergency Vent	8 or 16	60,994	Colorado Engineering Experiment Station Inc., 2014
3"	244OMS	Male Threads	Emergency Vent w/ Screen	8 or 16	51,076	Colorado Engineering Experiment Station Inc., 2014
3"	244O	Female Threads	Emergency Vent	8 or 16	60,994	Colorado Engineering Experiment Station Inc., 2014
3"	244OS	Female Threads	Emergency Vent w/ Screen	8 or 16	51,076	Colorado Engineering Experiment Station Inc., 2014
3"	245M	Male Threads	Emergency Vent	8	67,162	Colorado Engineering Experiment Station Inc., 2018
3"	245MS	Male Threads	Emergency Vent w/ Screen	8	56,241	Colorado Engineering Experiment Station Inc., 2018
3"	245	Female Threads	Emergency Vent	8	67,162	Colorado Engineering Experiment Station Inc., 2018
3"	245S	Female Threads	Emergency Vent w/ Screen	8	56,241	Colorado Engineering Experiment Station Inc., 2018
3"	354	Female Slip On	Updraft Vent	0	59,000	Tested at Univ. Wisconsin Platteville by L. Lee, 1996
3"	749	Female Thds/Slip On	Pressure Vacuum Vent	8	8,500	Tested at Univ. of Wisconsin Platteville by L. Lee, 1988
3"	749	Female Thds/Slip On	Pressure Vacuum Vent	12	8,500	Tested at Univ. of Wisconsin Platteville by L. Lee, 1988
3"	749 CRB	Female Thds/Slip On	Pressure Vacuum Vent	1.70	11,000	Tested at Univ. of Wisconsin Platteville by L. Lee, 1996
3"	748A	Female Threads	Pressure Vacuum Vent	2, 4, 6, or 8	43,000	Based on ISU Test of 3" 548 - 8 oz. by Kavanagh, 1990
3"	748A	Female Threads	Pressure Vacuum Vent	12 or 16	40,000	Based on ISU Test of 3" 548 - 16 oz. by Kavanagh, 1990
3"	922	Female Threads	Pressure Vacuum Vent Alarm	6	44,160	Tested at Environ Laboratories, 2006
3"	922	Female Threads	Pressure Vacuum Vent Alarm	8	43,080	Tested at Environ Laboratories, 2006

(TABLE CONTINUES ON PAGE 16)

Table I: Vent Capacity (continued from page 15)

Size	Item Number	Mounting Connection	Description	Pressure (oz/sq in.)	Capacity (SCFH)	Data Source
4"	244OM	Male Threads	Emergency Vent	8 or 16	131,700	Colorado Engineering Experiment Station Inc., 2014
4"	244OMS	Male Threads	Emergency Vent w/ Screen	8 or 16	117,160	Colorado Engineering Experiment Station Inc., 2014
4"	244O	Female Threads	Emergency Vent	8 or 16	131,700	Colorado Engineering Experiment Station Inc., 2014
4"	244OS	Female Threads	Emergency Vent w/ Screen	8 or 16	117,160	Colorado Engineering Experiment Station Inc., 2014
4"	245M	Male Threads	Emergency Vent	8	129,369	Colorado Engineering Experiment Station Inc., 2018
4"	245MS	Male Threads	Emergency Vent w/ Screen	8	115,086	Colorado Engineering Experiment Station Inc., 2018
4"	245	Female Threads	Emergency Vent	8	129,369	Colorado Engineering Experiment Station Inc., 2018
4"	245S	Female Threads	Emergency Vent w/ Screen	8	115,086	Colorado Engineering Experiment Station Inc., 2018
4"	245F	Flanged	Emergency Vent	8	129,369	Colorado Engineering Experiment Station Inc., 2018
4"	245FS	Flanged	Emergency Vent w/ Screen	8	115,086	Colorado Engineering Experiment Station Inc., 2018
4"	354	Female Slip On	Updraft Vent	0	116,900	Tested at Continental Disc Corp, 1997
5"	244O	Female Threads	Emergency Vent	8 or 16	190,087	Colorado Engineering Experiment Station Inc., 2014
5"	244OS	Female Threads	Emergency Vent w/ Screen	8 or 16	165,756	Colorado Engineering Experiment Station Inc., 2014
5"	244OM	Male Threads	Emergency Vent	8 or 16	190,087	Colorado Engineering Experiment Station Inc., 2014
5"	244OMS	Male Threads	Emergency Vent w/ Screen	8 or 16	165,756	Colorado Engineering Experiment Station Inc., 2014
6"	244O	Female Threads	Emergency Vent	8 or 16	299,684	Colorado Engineering Experiment Station Inc., 2014
6"	244OS	Female Threads	Emergency Vent w/ Screen	8 or 16	250,236	Colorado Engineering Experiment Station Inc., 2014
6"	244OF	Flanged	Emergency Vent	8 or 16	299,684	Colorado Engineering Experiment Station Inc., 2014
6"	244OFS	Flanged	Emergency Vent w/ Screen	8 or 16	250,236	Colorado Engineering Experiment Station Inc., 2014
6"	244OM	Male Threads	Emergency Vent	8 or 16	299,684	Colorado Engineering Experiment Station Inc., 2014
6"	244OMS	Male Threads	Emergency Vent w/ Screen	8 or 16	250,236	Colorado Engineering Experiment Station Inc., 2014
6"	245M	Male Threads	Emergency Vent	8	331,750	Colorado Engineering Experiment Station Inc., 2018
6"	245MS	Male Threads	Emergency Vent w/ Screen	8	277,011	Colorado Engineering Experiment Station Inc., 2018
6"	245	Female Threads	Emergency Vent	8	331,750	Colorado Engineering Experiment Station Inc., 2018
6"	245S	Female Threads	Emergency Vent w/ Screen	8	277,011	Colorado Engineering Experiment Station Inc., 2018
6"	245F	Flanged	Emergency Vent	8	331,750	Colorado Engineering Experiment Station Inc., 2018
6"	245FS	Flanged	Emergency Vent w/ Screen	8	277,011	Colorado Engineering Experiment Station Inc., 2018
8"	244O	Female Threads	Emergency Vent	8 or 16	503,517	Colorado Engineering Experiment Station Inc., 2014
8"	244OF	Flanged	Emergency Vent	8 or 16	503,517	Colorado Engineering Experiment Station Inc., 2014
8"	244OM	Male Threads	Emergency Vent	8 or 16	503,517	Colorado Engineering Experiment Station Inc., 2014
8"	245M	Male Threads	Emergency Vent	8	527,441	Colorado Engineering Experiment Station Inc., 2018
8"	245	Female Threads	Emergency Vent	8	527,441	Colorado Engineering Experiment Station Inc., 2018
8"	245F	Flanged	Emergency Vent	8	527,441	Colorado Engineering Experiment Station Inc., 2018
10"	244OF	Flanged	Emergency Vent	8 or 16	890,275	Colorado Engineering Experiment Station Inc., 2014
10"	245F	Flanged	Emergency Vent	8	972,110	Colorado Engineering Experiment Station Inc., 2018



VENT SELECTION



UL
2583



Fig.244O



Fig.244OM

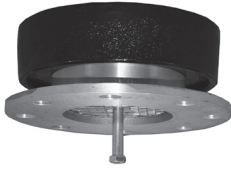

Fig.244OF

NOTE

Use EVR models to comply with pressure decay test. Contact factory for assistance.

244 Series Emergency Vent

Application

UL Listed emergency vent (pressure relief only) used on aboveground storage tanks, as a code requirement, to help prevent the tank from becoming over-pressurized and possibly rupturing if ever exposed to fire. The vent must be used in conjunction with a "normal vent." Correct application of this vent requires proper vent size and selection for the tank system in order to meet the specific venting capacity.

Materials of Construction

2" Vent

Body... Aluminum or brass
Cover... Aluminum or brass
O-Ring... FKM
Screen... 4 mesh stainless steel (optional)
Center Pin... Zinc-plated steel

3", 4", 5", 6", 8", 10" Vents

Body... Aluminum
Cover... Powder coated cast iron
O-Ring... FKM-A, standard models
O-Ring... FKM-B, Model numbers ending in AVE or AVEVR
Screen... 3 mesh stainless steel (3", 4", 5" and 6") (optional)

Code Compliance

When properly sized for the tank, this vent will conform to the requirements of the International Fire Code; National Fire Code of Canada; National Fire Protection Agency—NFPA 20, 30, 30A, 31, 37, 110; Petroleum Equipment Institute—PEI RP200, PEI RP800; Underwriters Laboratories Inc.—UL-142, UL-2085, UL-2244; Underwriters Laboratories of Canada—CAN/ULC S601, CAN/ULC S602, CAN/ULC S652

Approvals

California Air Resource Board (CARB) Phase 1 Enhanced Vapor Recovery (EVR) AST Certified Products (VR-402-B); UL 2583 Listed (*10 inch 2.5oz vent is UL Listed, but NOT Listed to UL 2583)

NOTE

Emergency vent should be set higher than the normal vent so the normal vent operates first.



Item Number	Size	Venting Capacity (*Est. SCFH @ 2.5 PSI)	Mounting Connection	Opening Pressure Setting (oz/in ²)	Weight (lbs)
244OM-0020 AV	2"	31,917	Male NPT	8	1.0
244OMA0030AVEVR		31,917	Male NPT	16	1.0
244O-0050 AV	3"	60,994	Female NPT	8	7.0
244O-0060 AV		60,994	Female NPT	16	11.50
244O-0060AVEVR		60,994	Female NPT	16	11.50
244OM-0050 AV		60,994	Male NPT	8	6.40
244OM-0060 AV		60,994	Male NPT	16	11.0
244OM-0060AVEVR		60,994	Male NPT	16	11.0
244O-0100 AV		4"	131,700	Female NPT	8
244O-0170 AV	131,700		Female NPT	16	18.0
244O-0170AVEVR	131,700		Female NPT	16	18.0
244OF-0170 AV	131,700		Flanged	16	20.0
244OF-0170AVEVR	131,700		Flanged	16	20.0
244OF-0600 AV	131,700		Flanged	8	11.0
244OF-0600 AVE	131,700		Flanged	8	11.0
244OM-0100 AV	131,700		Male NPT	8	10.0
244OM-0170 AV	131,700		Male NPT	16	19.0
244OM-0170AVEVR	131,700		Male NPT	16	19.0
Flange = 9" OD; eight (8) .75" diameter holes on 7.5" diameter B.C.					
244O-0800 AV	5"	190,087	Female NPT	8	14.0
244O-0900 AV		190,087	Female NPT	16	27.0
244O-0900AVEVR		190,087	Female NPT	16	27.0
244OM-0800 AV		190,087	Male NPT	8	15.0
244OM-0900 AV		190,087	Male NPT	16	28.0
244OM-0900AVEVR		190,087	Male NPT	16	28.0

Item Number	Size	Venting Capacity (*Est. SCFH @ 2.5 PSI)	Mounting Connection	Opening Pressure Setting (oz/in ²)	Weight (lbs)
244O-0200 AV	6"	299,684	Female NPT	8	20.0
244O-0200AVEVR		299,684	Female NPT	8	20.0
244O-0400 AV		299,684	Female NPT	16	36.0
244O-0400AVEVR		299,684	Female NPT	16	36.0
244OF-0050 AV		299,684	Flanged	8	22.0
244OF-0050AVEVR		299,684	Flanged	8	22.0
244OF-0075 AV		299,684	Flanged	16	38.0
244OF-0075AVEVR		299,684	Flanged	16	38.0
244OM-0200 AV		299,684	Male NPT	8	21.0
244OM-0200AVEVR		299,684	Male NPT	8	21.0
244OM-0400 AV	6"	299,684	Male NPT	16	37.0
244OM-0400AVEVR		299,684	Male NPT	16	37.0
Flange = 11" OD ; eight (8) .88" Diameter holes on 9.5" diameter B.C.					
244O-0600 AV	8"	503,517	Female NPT	8	33.0
244O-0600 AVE		503,517	Female NPT	8	33.0
244O-0700 AV		503,517	Female NPT	16	62.0
244O-0700 AVEVR		503,517	Female NPT	16	62.0
244OF-0100 AV		503,517	Flanged	8	33.0
244OF-0100AVEVR		503,517	Flanged	8	33.0
244OF-0200 AV		503,517	Flanged	16	67.0
244OF-0200AVEVR		503,517	Flanged	16	67.0
244OM-0600 AV		503,517	Male NPT	8	34.0
244OM-0600 AVEVR		503,517	Male NPT	8	34.0
244OM-0700 AV	8"	503,517	Male NPT	16	63.0
244OM-0700 AVEVR		503,517	Male NPT	16	63.0
Flange = 14" OD ; eight (8) .88" Diameter holes on 11.75" diameter B.C.					
244OF-0300 AV	10"	881,670	Flanged	2.5	25.0
244OF-0400 AV		890,275	Flanged	8	57.0
244OF-0400AVEVR		890,275	Flanged	8	57.0
244OF-0500 AV		890,275	Flanged	16	103.0
244OF-0500AVEVR		890,275	Flanged	16	103.0

WARNING: The 244 emergency vent is for "emergency pressure relief only" and must be used in conjunction with a "normal vent" or pressure vacuum vent such as a Morrison Fig. 354,748, 948A, 749 or 922. The 244 emergency vent must be properly sized and selected for each specific tank application in order to meet the proper "venting capacity" requirements. See the Morrison Vent Guide for further instructions.

WARNING: DO NOT FILL OR UNLOAD FUEL FROM A STORAGE TANK UNLESS IT IS CERTAIN THAT THE TANK VENTS WILL OPERATE PROPERLY. Morrison tank vents are designed only for use on shop fabricated atmospheric tanks which have been built and tested in accordance with UL 142, NFPA 30 & 30A, and API 650 and in accordance with all applicable local, state and federal laws. In normal operation, dust and debris can accumulate in vent openings and block air passages. Certain atmospheric conditions such as a sudden drop in temperature, below freezing temperatures, and freezing rain can cause moisture to enter the vent and freeze which can restrict internal movement of vent mechanisms and block air passages. All storage tank vent air passages must be completely free of restriction and all vent mechanisms must have free movement in order to insure proper operation. Any restriction of airflow can cause excessive pressure or vacuum to build up in the storage tank, which can result in structural damage to the tank, fuel spillage, property damage, fire, injury, and death. Monthly inspection, and immediate inspection during freezing conditions, by someone familiar with the proper operation of storage tank vents, is required to insure venting devices are functioning properly before filling or unloading a tank. Normal vents such as pressure vacuum and updraft vents for aboveground storage tanks should be sized according to NFPA 30 (2018) 21.4.3



UL
2583

245 Series Lightweight Emergency Vent



Application

This lightweight, spring-loaded emergency vent (pressure relief only) is used on aboveground storage tanks, as a code requirement, to help prevent the tank from becoming over-pressurized and possibly rupturing if ever exposed to fire. This vent must be used in conjunction with a "normal vent." Correct application of this vent requires proper vent size and selection for the tank system in order to meet the specific venting capacity.

Materials of Construction

- Body... Aluminum
- Cover... Aluminum
- Seat... FKM
- Bolt... Zinc plated steel
- Spring... Stainless steel

Code Compliance

When properly sized for the tank, this vent will conform to the requirements of the International Fire Code; National Fire Code of Canada; National Fire Protection Agency—NFPA 30, 30A, 31, 37, 110; Petroleum Equipment Institute—PEI RP200, PEI RP800; Underwriters Laboratories Inc.—UL-142, UL-2085, UL-2244; Underwriters Laboratories of Canada—CAN/ULC S601, CAN/ULC S602, CAN/ULC S652

Approvals

UL 2583 Listed

NOTE

Emergency vent should be set higher than the normal vent so the normal vent operates first.

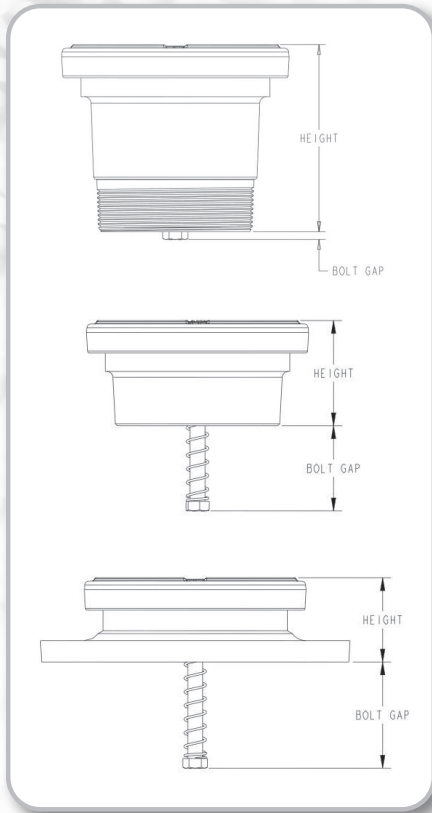

Item Number	Size	Venting Capacity (*Est. SCFH @ 2.5 PSI)	Mounting Connection	Opening Pressure Setting (oz/in ²)	Height	Bolt Gap	Weight (lbs)
245M--0200 AV	2"	31,917	Male NPT	8	1.50"	1.60"	0.50
245---0300 AV	3"	67,162	Female NPT	8	2.80"	0.90"	2.80
245M--0300 AV		67,162	Male NPT	8	3.60"	< ¼"	2.50
245---0400 AV	4"	129,369	Female NPT	8	3.10"	2.50"	3.30
245M--0400 AV		129,369	Male NPT	8	5.40"	< ¼"	4.50
245F--0400 AV †		129,369	Flanged	8	2.50"	3.00"	6.00
245---0600 AV	6"	331,750	Female NPT	8	3.40"	2.60"	5.50
245M--0600 AV		331,750	Male NPT	8	5.40"	0.20"	6.20
245F--0600 AV †		331,750	Flanged	8	2.90"	3.20"	9.10
245--0800 AV	8"	527,441	Female NPT	8	4.50"	1.50"	9.20
245M--0800 AV		527,441	Male NPT	8	5.70"	0.40"	10.10
245F--0800 AV †		527,441	Flanged	8	3.30"	2.90"	14.50
245F--1000 AV †	10"	972,110	Flanged	8	2.80"	6.00"	20.00

WARNING: The 245 lightweight emergency vent is for "emergency pressure relief only" and must be used in conjunction with a "normal vent" or pressure vacuum vent such as a Morrison Fig. 354,748, 948A, 749 or 922. The 245 lightweight emergency vent must be properly sized and selected for each specific tank application in order to meet the proper "venting capacity" requirements. See the Morrison Vent Guide for further instructions.

WARNING: DO NOT FILL OR UNLOAD FUEL FROM A STORAGE TANK UNLESS IT IS CERTAIN THAT THE TANK VENTS WILL OPERATE PROPERLY.

Morrison tank vents are designed only for use on shop fabricated atmospheric tanks which have been built and tested in accordance with UL 142, NFPA 30 & 30A, and API 650 and in accordance with all applicable local, state and federal laws. In normal operation, dust and debris can accumulate in vent openings and block air passages. Certain atmospheric conditions such as a sudden drop in temperature, below freezing temperatures, and freezing rain can cause moisture to enter the vent and freeze which can restrict internal movement of vent mechanisms and block air passages. All storage tank vent air passages must be completely free of restriction and all vent mechanisms must have free movement in order to insure proper operation. Any restriction of airflow can cause excessive pressure or vacuum to build up in the storage tank, which can result in structural damage to the tank, fuel spillage, property damage, fire, injury, and death. Monthly inspection, and immediate inspection during freezing conditions, by someone familiar with the proper operation of storage tank vents, is required to insure venting devices are functioning properly before filling or unloading a tank. Normal vents such as pressure vacuum and updraft vents for aboveground storage tanks should be sized according to NFPA 30 (2018) 21.4.3



244A Flanged Adaptor



Application

Flange adaptors are welded to tank top openings in aboveground storage tanks creating a flanged emergency vent connection.

Features

- Pre-drilled for easy installation of emergency vent
- Gaskets, nuts, and bolts are available

Materials of Construction

Body... Carbon steel

Item Number	Size	OAL	Weight (lbs)
244A--0400 1A	4" (eight 3/4" holes on 7 1/2" B.C.)	5"	10.0
244A--0000 1A	6" (eight 7/8" holes on 9 1/2" B.C.)	8"	12.0
244A--0100 1A	8" (eight 7/8" holes on 11 3/4" B.C.)	8"	19.0
244A--0200 1A	10" (twelve 1" holes on 14 1/4" B.C.)	10"	20.0

244C Companion Flange



This companion flange has female threads and is designed to convert a male threaded pipe nipple to a 150# raised face flange connection.

Materials of Construction

Body...Cast iron with female NPT "center port" I.D.

Item Number	Size	Weight (lbs)
244C--0100 1F	8" (eight 7/8" holes on 11 3/4" B.C. w/8" NPT I.D.)	27.0
244C--0200 1F	10" (twelve 1" holes on 14 1/4" B.C. w/10" NPT I.D.)	36.0

244N Pipe Nipple

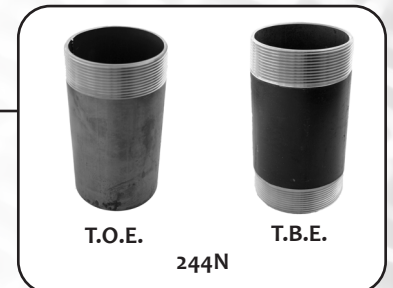

Female threads designed to convert a male threaded pipe nipple to a 150# raised face flange connection.

Materials of Construction

Cast iron with female NPT "center port" I.D.

Item Number	Size	Threads	Weight (lbs)
244N--0100 1N	4" x 8"	T.O.E	7.0
244N--0200 1N	6" x 8"	T.O.E	13.0
244N--0300 1N	8" x 12"	T.O.E	28.0
244N--0600 1N	4" x 8"	T.B.E	7.0
244N--0700 1N	6" x 8"	T.B.E	13.0
244N--0800 1N	8" x 12"	T.B.E	28.0
244N--1000 1N	8" x 8"	T.O.E	20.0
244N--1100 1N	8" x 8"	T.B.E	20.0



748A

748A Series Pressure/Vacuum Vent

Application

This pressure vacuum vent is designed for installation on top of the vent pipe of an aboveground or underground storage tank. Poppets seal vapors in the tank when pressure is equalized. The vent allows the tank to "breathe" during filling and dispensing operations.

Features

- Directs vapors outward and upward in compliance with NFPA 30
- Tri-polar design for mounting exhaust hood in any of three positions
- Optional dryer connections accommodate the installation of desiccant dryers on vacuum connection
- Optional pressure discharge hood facilitates piping pressure relief to desired discharge point
- Settings are approximate

NOTE

Normal vents such as pressure vacuum and updraft vents for aboveground storage tanks should be sized according to NFPA 30 (2018) 21.4.3.3

Materials of Construction

Body and hood... Aluminum
 Seats... Passivated aluminum
 Poppets... Brass
 Screens... Stainless steel

Item Number	Size	Venting Capacity (SCFH) (@ 2.5 PSI)	Pressure Setting (oz./in ²)	Vacuum Setting (oz./in ²)	Weight (lbs)
748A--0100 AV	2"	20,200	2.0	1.0	6.50
748A--0200 AV		20,200	4.0	1.0	7.15
748A--0300 AV		20,200	6.0	1.0	7.55
748A--0400 AV		20,200	8.0	1.0	8.15
748A--0500 AV		18,600	12.0	1.0	9.30
748A--0600 AV		18,600	16.0	1.0	10.35
748A--3100 AV	3"	43,000	2.0	1.0	9.75
748A--3200 AV		43,000	4.0	1.0	11.15
748A--3300 AV		43,000	6.0	1.0	12.15
748A--3400 AV		43,000	8.0	1.0	13.10
748A--3500 AV		40,000	12.0	1.0	15.30
748A--3600 AV		40,000	16.0	1.0	17.75

*Consult Price List for other options including male threaded dryer connection and female threaded pressure discharge hood.

WARNING: DO NOT FILL OR UNLOAD FUEL FROM A STORAGE TANK UNLESS IT IS CERTAIN THAT THE TANK VENTS WILL OPERATE PROPERLY.

Morrison tank vents are designed only for use on shop fabricated atmospheric tanks which have been built and tested in accordance with UL 142, NFPA 30 & 30A, and API 650 and in accordance with all applicable local, state and federal laws. In normal operation, dust and debris can accumulate in vent openings and block air passages. Certain atmospheric conditions such as a sudden drop in temperature, below freezing temperatures, and freezing rain can cause moisture to enter the vent and freeze which can restrict internal movement of vent mechanisms and block air passages. All storage tank vent air passages must be completely free of restriction and all vent mechanisms must have free movement in order to insure proper operation. Any restriction of airflow can cause excessive pressure or vacuum to build up in the storage tank, which can result in structural damage to the tank, fuel spillage, property damage, fire, injury, and death. Monthly inspection, and immediate inspection during freezing conditions, by someone familiar with the proper operation of storage tank vents, is required to insure venting devices are functioning properly before filling or unloading a tank. Normal vents such as pressure vacuum and updraft vents for aboveground storage tanks should be sized according to NFPA 30 (2018) 21.4.3



748ALT Series Pressure/Vacuum Vent



748ALT

Application

The 748ALT pressure vacuum vent valve is used with aqua-ammonia and ag-chemical products allowing the tank to "breathe" during filling and dispensing operations. Pressure and vacuum poppets seal vapors in the tank when pressure is equalized.

Features

- Settings are approximate
- Conserves vapors
- Tri-polar design for mounting exhaust hood in any of three positions

Materials of Construction

Body and hood... Aluminum

Seats and poppets... PTFE coated aluminum

Screens... Stainless steel

NOTE

Normal vents such as pressure vacuum and updraft vents for aboveground storage tanks should be sized according to NFPA 30 (2018) 21.4.3.3

Item Number	Size	Pressure Setting (oz./in ²)	Vacuum Setting (oz./in ²)	Venting Capacity (SCFH) (@ 2.5 PSI)	Weight (lbs)
748ALT0100 AV	2"	8.0	1.0	20,200	5.50
748ALT0200 AV	2"	16.0	1.0	18,000	5.50
748ALT0300 AV	2"	32.0	1.0	--	5.50

**Consult Price List for other options including male threaded dryer connection and female threaded pressure discharge hood.*

WARNING: DO NOT FILL OR UNLOAD FUEL FROM A STORAGE TANK UNLESS IT IS CERTAIN THAT THE TANK VENTS WILL OPERATE PROPERLY.

Morrison tank vents are designed only for use on shop fabricated atmospheric tanks which have been built and tested in accordance with UL 142, NFPA 30 & 30A, and API 650 and in accordance with all applicable local, state and federal laws. In normal operation, dust and debris can accumulate in vent openings and block air passages. Certain atmospheric conditions such as a sudden drop in temperature, below freezing temperatures, and freezing rain can cause moisture to enter the vent and freeze which can restrict internal movement of vent mechanisms and block air passages. All storage tank vent air passages must be completely free of restriction and all vent mechanisms must have free movement in order to insure proper operation. Any restriction of airflow can cause excessive pressure or vacuum to build up in the storage tank, which can result in structural damage to the tank, fuel spillage, property damage, fire, injury, and death. Monthly inspection, and immediate inspection during freezing conditions, by someone familiar with the proper operation of storage tank vents, is required to insure venting devices are functioning properly before filling or unloading a tank. Normal vents such as pressure vacuum and updraft vents for aboveground storage tanks should be sized according to NFPA 30 (2018) 21.4.3



749

NOTE

Morrison 749 P/V vent must only be used in conjunction with motor fueling and/or low capacity flow. Fluid handling in lines larger than that used for retail service stations can cause tank to rupture or implode.

749 Series Pressure/Vacuum Vent

Application

Pressure vacuum vents are installed on the top of underground and low volume aboveground storage tank vent pipes. Vent allows tank to “breathe” during filling and discharging operations. Pressure and vacuum poppets seal vapors in tank when pressure is equalized. Settings are approximate.

Features

- Screen protects the tank from debris and insects
- Integrated internal drain port channels water away from the tank
- Vent vapors up and outward per NFPA 30
- Conserves fuel
- Certified SCFH ratings

Materials of Construction

Body and hood... Anodized aluminum
 Pressure poppet... Anodized aluminum
 Vacuum poppet... Brass vacuum
 Body seal... Buna-N
 Screen... 40 mesh stainless steel
 Springs... Stainless steel
 Set screws... Zinc-plated steel

Certifications and Listings

CARB 95-14 (749CRB0500 model); CARB 95-15 (749CRB0600 model);
 CARB 96-19 (749CRBS0600 model); 749CRB Pressure Vacuum Vents (models 749CRB0600 AV, 749CRB1600 AV, 749CRBS0600 AV, and 749CRBS1600 AV) meet the requirements of EPA 40 CFR part 63 for Gasoline Dispensing Facilities

Item Number	Size	Connection	Pressure Setting (oz./in ²)	Vacuum Setting (oz./in ²)	Venting Capacity (SCFH) (@ 2.5 PSI)	Weight (lbs)
749--0100 AV	2"	Threaded	8.0	0.5	8,500	1.0
749--0200 AV	2"	Threaded	12.0	0.5	8,500	1.0
749--1100 AV	3"	Threaded	8.0	0.5	8,500	1.55
749--1200 AV	3"	Threaded	12.0	0.5	8,500	1.55
749S--0100 AV	2"	Slip-on	8.0	0.5	8,500	1.0
749S--0200 AV	2"	Slip-on	12.0	0.5	8,500	1.0
749S--1100 AV	3"	Slip-on	8.0	0.5	8,500	1.55
749S--1200 AV	3"	Slip-on	12.0	0.5	8,500	1.55
749CRB0500 AV	2"	Threaded	8.0	5.0	11,000	1.45
749CRB0600 AV ♦	2"	Threaded	3" W.C.	8" W.C.	11,000	1.95
749CRB1500 AV ♦	3"	Threaded	8.0	5.0	8,500	1.65
749CRB1600 AV ♦	3"	Threaded	3" W.C.	8" W.C.	11,000	1.65
749CRBS600 AV	2"	Slip-on	3" W.C.	8" W.C.	11,000	1.45
749CRBS1600 AV ♦	3"	Slip-on	3" W.C.	8" W.C.	11,000	1.95

♦ Meet the requirements of EPA 40 CFR part 63 for Gasoline Dispensing Facilities.

WARNING: DO NOT FILL OR UNLOAD FUEL FROM A STORAGE TANK UNLESS IT IS CERTAIN THAT THE TANK VENTS WILL OPERATE PROPERLY.

Morrison tank vents are designed only for use on shop fabricated atmospheric tanks which have been built and tested in accordance with UL 142, NFPA 30 & 30A, and API 650 and in accordance with all applicable local, state and federal laws. In normal operation, dust and debris can accumulate in vent openings and block air passages. Certain atmospheric conditions such as a sudden drop in temperature, below freezing temperatures, and freezing rain can cause moisture to enter the vent and freeze which can restrict internal movement of vent mechanisms and block air passages. All storage tank vent air passages must be completely free of restriction and all vent mechanisms must have free movement in order to insure proper operation. Any restriction of airflow can cause excessive pressure or vacuum to build up in the storage tank, which can result in structural damage to the tank, fuel spillage, property damage, fire, injury, and death. Monthly inspection, and immediate inspection during freezing conditions, by someone familiar with the proper operation of storage tank vents, is required to insure venting devices are functioning properly before filling or unloading a tank. Normal vents such as pressure vacuum and updraft vents for aboveground storage tanks should be sized according to NFPA 30 (2018) 21.4.3



922 Series Combination Vent/Overfill Alarm

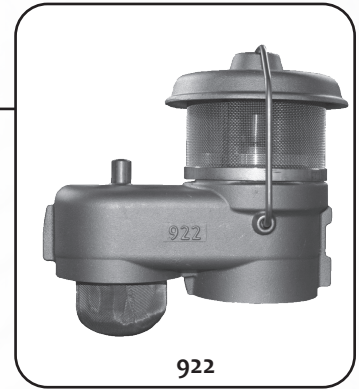

Application

The audible alarm whistles when the liquid level in the aboveground storage tank reaches the preset level. The pressure vacuum vent allows the tank to “breathe” during filling and dispensing operations.

Features

- Functions as both a pressure vacuum vent and audible alarm while utilizing a single 2” or 3” tank opening. Installs on the top of the vent pipe, generally 12 feet above grade
- 105 to 120 decibel whistle alarm (measured at a distance of 1 foot with a fill rate of 90 GPM)
- Fully mechanical alarm does not require electricity or batteries
- The alarm level can be set to activate at any liquid level by adjusting the cable length to the float device
- Minimum fill rate of 20 GPM required for alarm to operate

Materials of Construction

Body... Anodized aluminum
 Screens... Stainless steel
 Rainguard... Aluminum
 Seals... FKM
 Ball... PTFE
 Float... Stainless steel

Certifications and Listings

Florida DEP EQ-227

NOTE
 922 not for use on vapor recovery systems.

Item Number	Size	Pressure Setting (oz/in ²)	Venting Capacity (SCFH) (@ 2.5 PSI)	dB Rating*	Weight (lbs)
922--0200 AA	2"	8 oz	30,300	120	8.50
922--0300 AA	3"	8 oz	43,020	120	6.30
922--0400 AA	2"	6 oz	30,120	110	8.50
922--0500 AA	3"	6 oz	44,160	105	6.30

WARNING: All emergency vents, fill connections, tank openings, and piping connections must be airtight. Alarm/vent airway must be free of any obstruction such as dirt or ice when filling or unloading tank. Emergency vent should be set at least 2 oz. higher than combination vent.

WARNING: DO NOT FILL OR UNLOAD FUEL FROM A STORAGE TANK UNLESS IT IS CERTAIN THAT THE TANK VENTS WILL OPERATE PROPERLY.
 Morrison tank vents are designed only for use on shop fabricated atmospheric tanks which have been built and tested in accordance with UL 142, NFPA 30 & 30A, and API 650 and in accordance with all applicable local, state and federal laws. In normal operation, dust and debris can accumulate in vent openings and block air passages. Certain atmospheric conditions such as a sudden drop in temperature, below freezing temperatures, and freezing rain can cause moisture to enter the vent and freeze which can restrict internal movement of vent mechanisms and block air passages. All storage tank vent air passages must be completely free of restriction and all vent mechanisms must have free movement in order to insure proper operation. Any restriction of airflow can cause excessive pressure or vacuum to build up in the storage tank, which can result in structural damage to the tank, fuel spillage, property damage, fire, injury, and death. Monthly inspection, and immediate inspection during freezing conditions, by someone familiar with the proper operation of storage tank vents, is required to insure venting devices are functioning properly before filling or unloading a tank. Normal vents such as pressure vacuum and updraft vents for aboveground storage tanks should be sized according to NFPA 30 (2018) 21.4.3



Fig. 352

352 End-of-Line, Open Air Deflagration Flame Arrester

Application

End-of-Line flame arresters are designed to be installed at the end connection of a tank vent line. The flame arrester provides a protection barrier that deters a flame generated from a source outside of the tank from flashing through the vent into the vapor space of the tank.

Features

- 304 stainless arrester plates provide long term corrosion resistance and durability
- Easy access for visual inspection and periodic maintenance
- Full 2" and 3" NPT vent line air flow capacity
- Water-resistant cover sheds water away from the vent line

Materials of Construction

Base.... 356 tempered aluminum

Cover... Aluminum

Arrester plates... 304 stainless steel

Threaded hardware... 18-8 stainless steel

Certifications and Listings

UL 525 Listed—Standard for Flame Arresters—Edition 8

NOTE
For petroleum storage tanks containing Group D* fluids.

**NFPA 70, the National Electrical Code, lists or defines hazardous gases, vapors, and dusts by "Groups." Consult these resources for information on Group D fluids.*

Item Number	Size	Venting Capacity (SCFH) (@2.5 PSI)	Weight (lbs)
352--0200 AA	2"	57,000	8.30
352--0300 AA	3"	117,000	16.20



351S & 748A Flame Arrester

Application

Flame arresters provide a positive barrier that deters flames from passing through the pressure vacuum vent line into a storage tank's vapor space.

Features

- Directs vapors outward and upward in accordance with NFPA 30
- Protects the vent line from debris and insects
- Tri-polar mounting screws for mounting exhaust hood in any of three positions
- Optional pressure discharge hood facilitates piping pressure relief to desired discharge point

Materials of Construction

351S

Body and cover... Cast iron
Arrester grid housing... Brass
Arrester plates... Stainless steel

748A

Body and hood... Aluminum
Poppets and seats... Brass
Screens... Stainless steel



Item Number	Size	Pressure Setting (oz./in ²)	Vacuum Setting (oz./in ²)	Venting Capacity (SCFH) (@2.5 PSI)	Weight (lbs)
351S--0200 AV	2"	2.0	1.0	15,500	42.0
351S--0300 AV	2"	4.0	1.0	15,500	42.50
351S--0400 AV	2"	6.0	1.0	15,500	42.75
351S--0500 AV	2"	8.0	1.0	15,500	43.50
351S--0600 AV	2"	12.0	1.0	13,000	44.50
351S--0700 AV	2"	16.0	1.0	13,000	45.75

*Consult Price List for other options including male threaded dryer connection and female threaded pressure discharge hood.

WARNING: Do not use with acetylene, carbon disulfide, etheleneoxide or hydrogen gases. For use with normal hydrocarbon flames such as gasoline in air. Routine inspection is required to ensure airways are clear and free of debris. Blocked airways can cause structural deformation of the tank.

WARNING: DO NOT FILL OR UNLOAD FUEL FROM A STORAGE TANK UNLESS IT IS CERTAIN THAT THE TANK VENTS WILL OPERATE PROPERLY.

Morrison tank vents are designed only for use on shop fabricated atmospheric tanks which have been built and tested in accordance with UL 142, NFPA 30 & 30A, and API 650 and in accordance with all applicable local, state and federal laws. In normal operation, dust and debris can accumulate in vent openings and block air passages. Certain atmospheric conditions such as a sudden drop in temperature, below freezing temperatures, and freezing rain can cause moisture to enter the vent and freeze which can restrict internal movement of vent mechanisms and block air passages. All storage tank vent air passages must be completely free of restriction and all vent mechanisms must have free movement in order to insure proper operation. Any restriction of airflow can cause excessive pressure or vacuum to build up in the storage tank, which can result in structural damage to the tank, fuel spillage, property damage, fire, injury, and death. Monthly inspection, and immediate inspection during freezing conditions, by someone familiar with the proper operation of storage tank vents, is required to insure venting devices are functioning properly before filling or unloading a tank. Normal vents such as pressure vacuum and updraft vents for aboveground storage tanks should be sized according to NFPA 30 (2018) 21.4.3



354

NOTE
Open vents will allow unrestricted evaporation of product.

354 Series Updraft Vent

Application

Atmospheric updraft vents are installed on the top of storage tank vent pipes on underground and aboveground fuel storage tanks.

Features

- Directs vapors outward and upward in accordance with NFPA 30
- Protects the vent line from debris and insects
- Water-resistant rain cap sheds water away from the vent line
- Slip-on design with set screws for easy installation
- Internal drain channels water penetration out through weep hole

Materials of Construction

Body and cap... Aluminum die cast

Screen... 40 mesh stainless steel

Certifications and Listings

CARB 89-12 (1½" and 2" models)

Item Number	Size (slip-on)	Venting Capacity (SCFH) (@ 2.5 PSI)	Weight (lbs)
354---0100 AV	1½"	27,650	0.75
354---0200 AV	2"	27,650	0.75
354---0300 AV	3"	59,000	1.50
354---0400 AV	4"	116,900	2.25



155S

NOTE
Open vents will allow unrestricted evaporation of product.

155 Series Double Outlet Vent

Application

Double outlet "T" style vents are used to cap the vent opening on fuel oil storage tanks.

Features

- Dual openings directed downward
- Screen keeps debris out of the tank
- **155** has NPT female threads
- **155S** is slip-on with set screw

Materials of Construction

Body... Aluminum

Screens... 20 mesh stainless steel

Set screw... Zinc plated steel

Item Number	Size	Weight (lbs)
155---0100 AV	¾"	0.25
155---0200 AV	1"	0.50
155---0300 AV	1¼"	0.50
155---0400 AV	1½"	0.75
155---0500 AV	2"	1.0
155---0600 AV	3"	2.50
155S--0100 AV	¾"	0.25
155S--0200 AV	1"	0.50
155S--0300 AV	1¼"	0.50
155S--0400 AV	1½"	0.75
155S--0500 AV	2"	1.0
155S--0600 AV	3"	2.50



Aboveground Fuel Storage - Pressure System

Rectangular double-wall tank with remote fill and side mounted dispenser

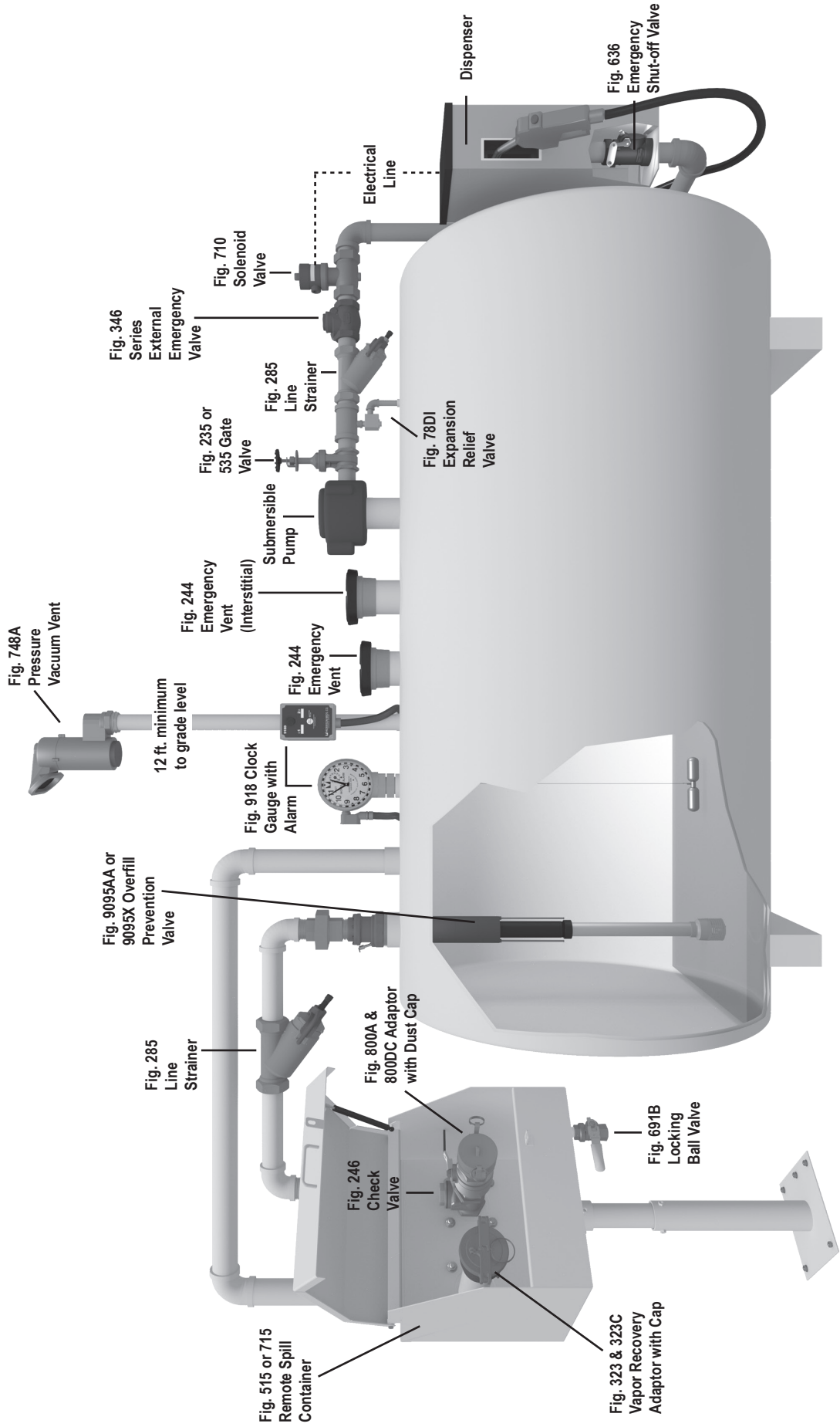



Aboveground Fuel Storage - Pressure System

Horizontal cylindrical tank with top fill and remote dispenser

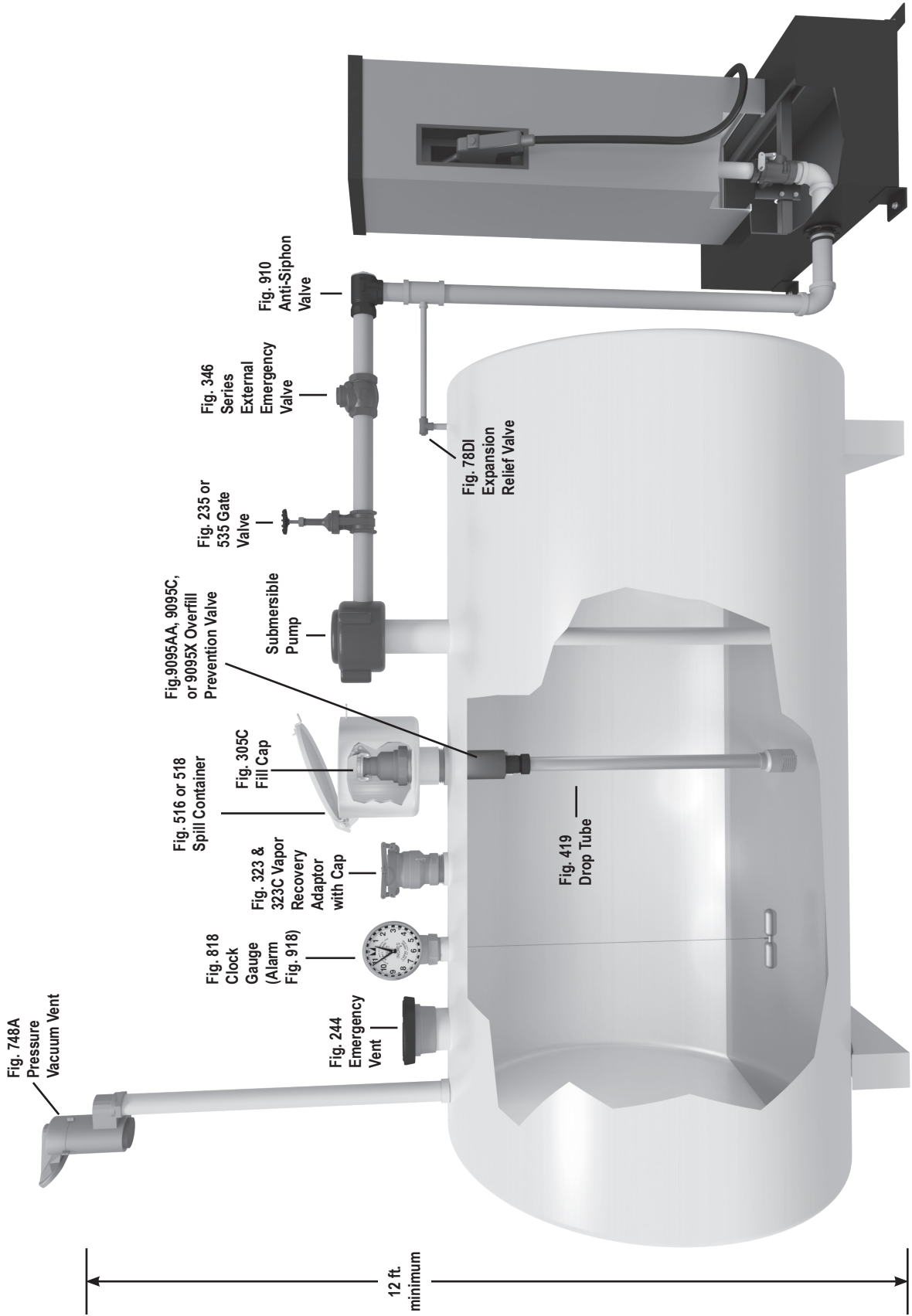



Aboveground Fuel Storage - Suction System

Rectangular double-wall tank with remote fill and remote pump

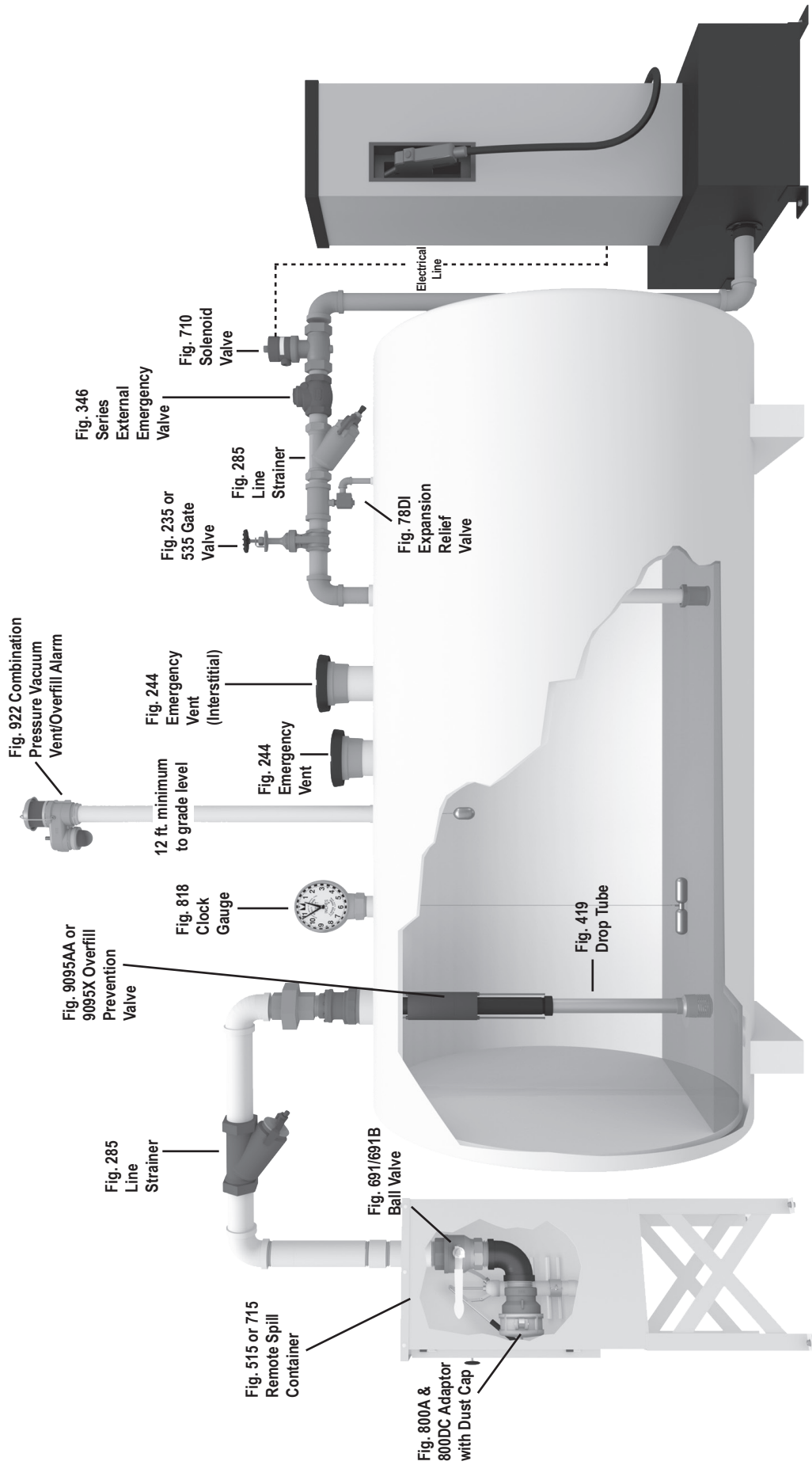



Aboveground Fuel Storage - Suction System

Horizontal cylindrical tank with top fill and top mounted pump

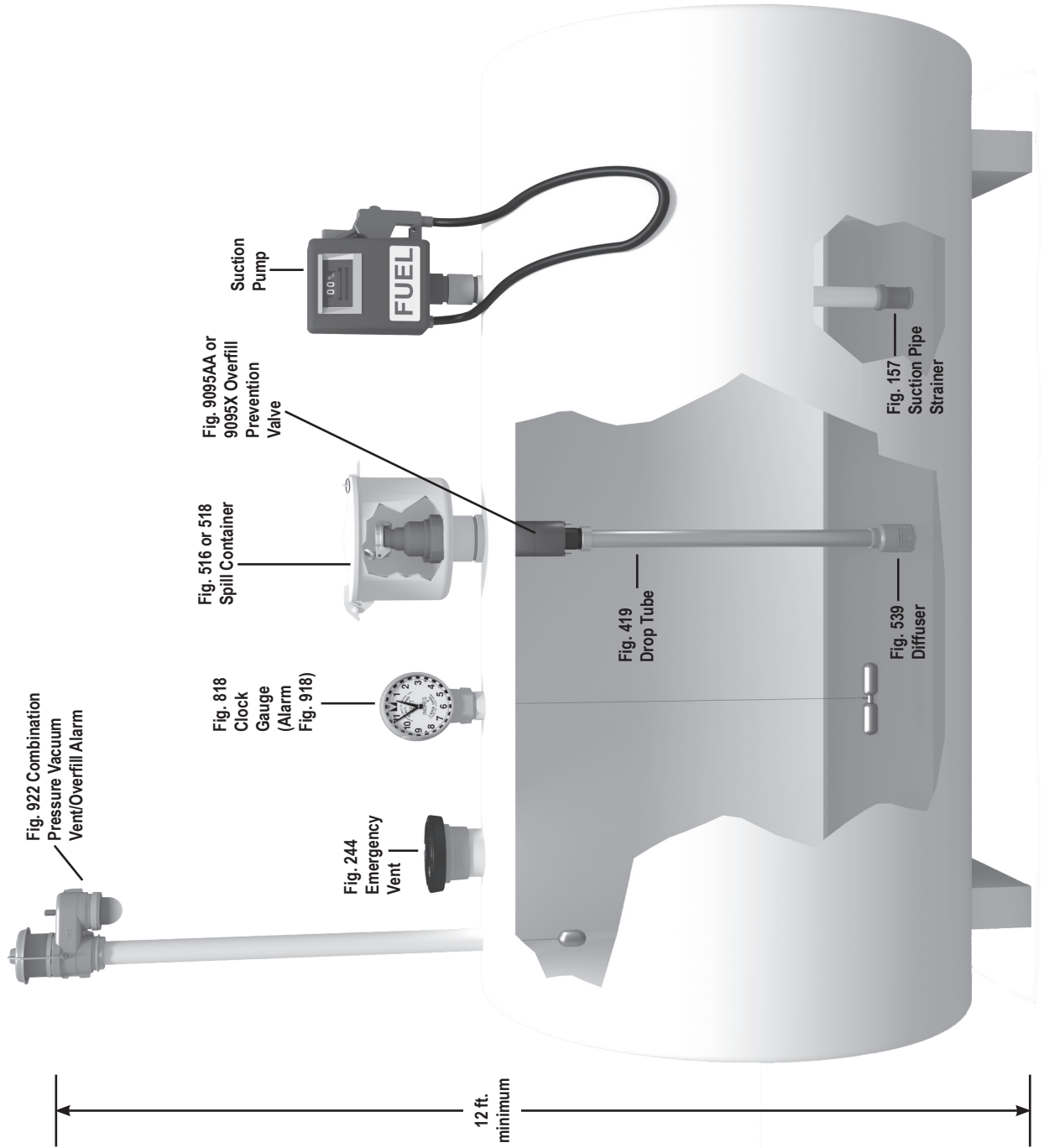



Emergency Generator or Fuel Oil Suction System

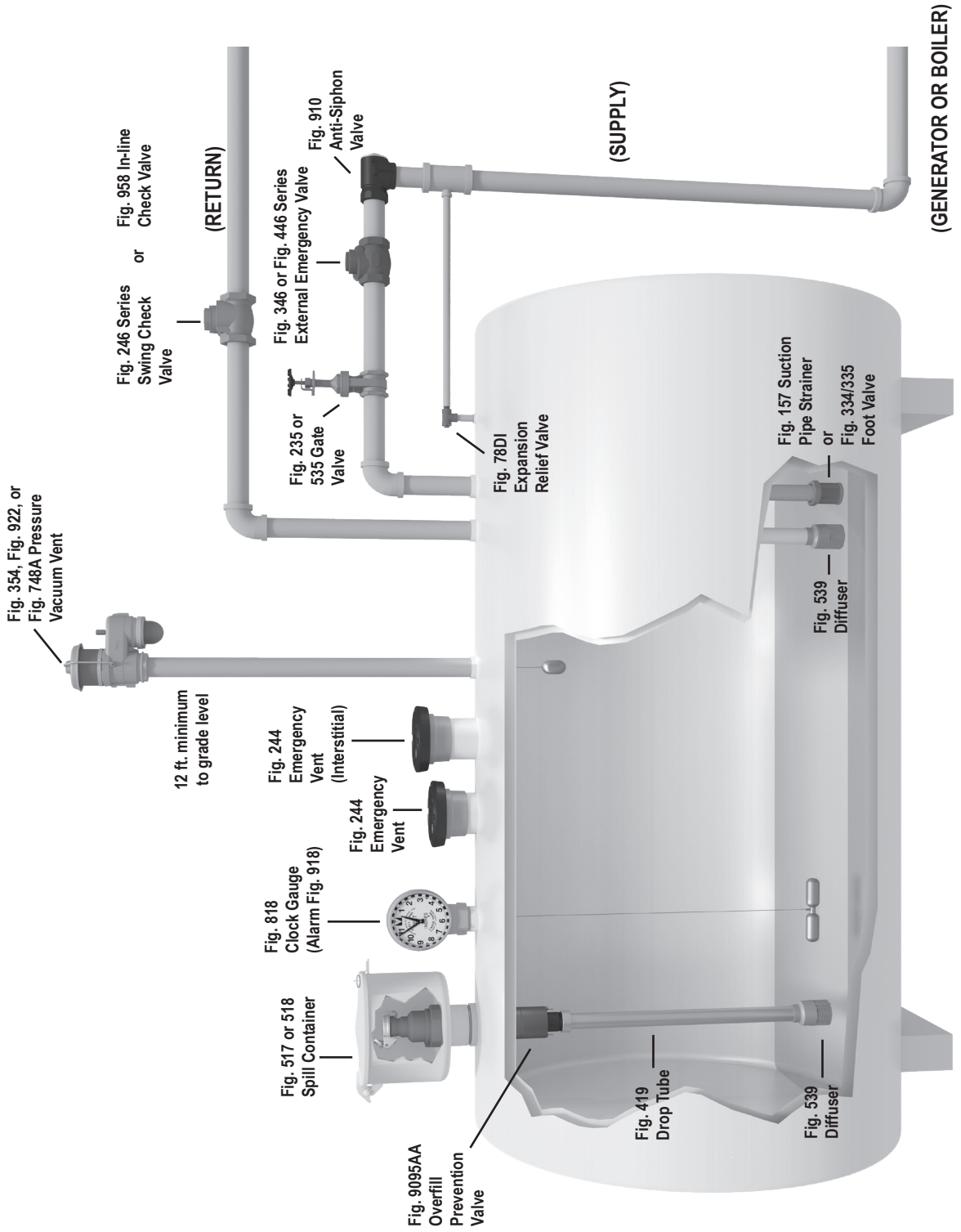



Aboveground Storage Tank - Bulk Storage

Fig. 922 Combination Vent/Overfill Alarm or 351 Flame Arrester/ Pressure Vacuum Vent or 748A or 948A Pressure

Fig. 1218S Tank Level Sensor

Fig. 2440 Series Emergency Vents

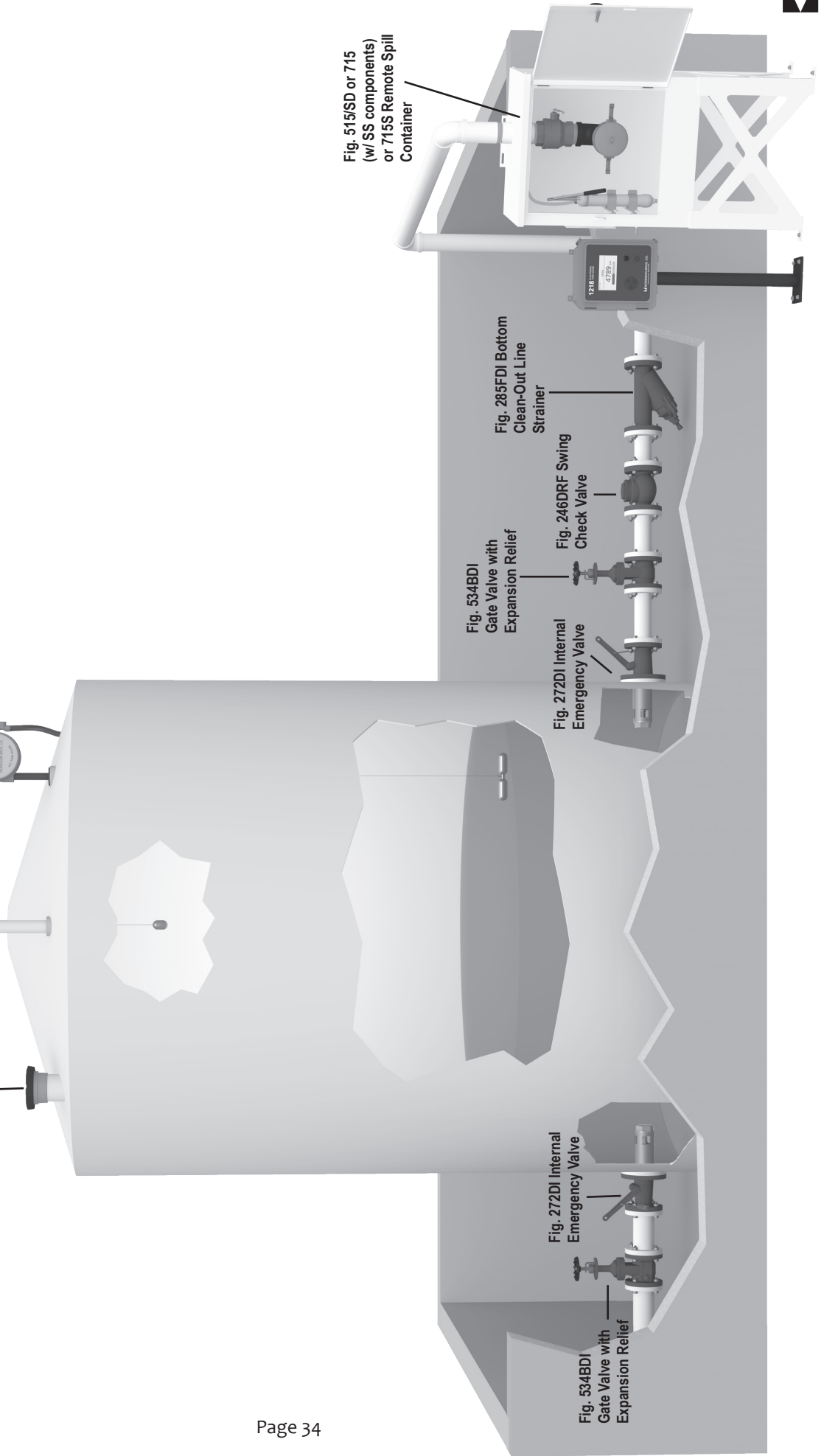

Fig. 515/SD or 715 (w/SS components) or 715S Remote Spill Container

Fig. 534BDI Gate Valve with Expansion Relief

Fig. 285FDI Bottom Clean-Out Line Strainer

Fig. 272DI Internal Emergency Valve

Fig. 272DI Internal Emergency Valve

Fig. 534BDI Gate Valve with Expansion Relief

Fig. 246DRF Swing Check Valve



 MORRISON BROS. CO.

570 E. 7th Street | Dubuque, IA 52001
t. 563.583.5701 | 800.553.4840 | f. 563.583.5028
custserv@morbros.com | www.morbros.com

2023