

Solenoid Valves

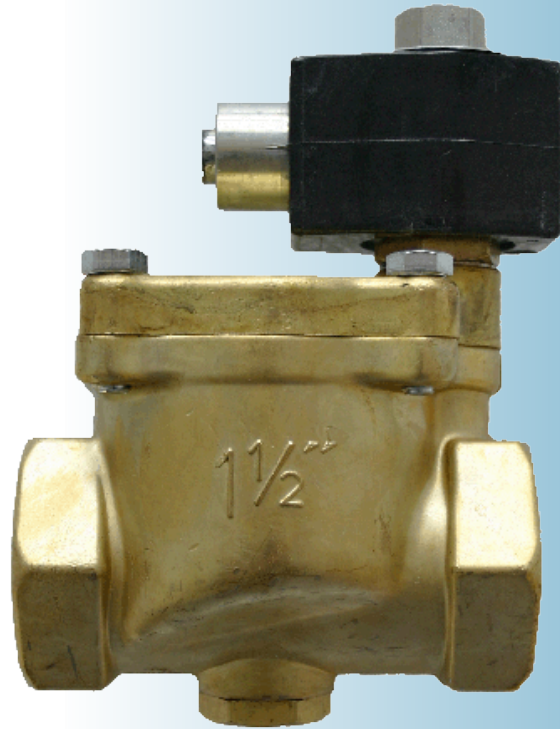

Solenoid valves are present in most fuel systems and in many industrial processing applications where liquid flow control is required. The proper valve selection saves valuable time and resources, ensures the best system performance and increases the life of the system.

This guide is designed to assist in the proper valve selection. Morrison Bros. Co. is committed to maintaining a significant inventory to better serve your needs. For additional assistance, contact Morrison Bros. Co. Customer service at custserv@morbros.com, or by calling us at 1-800-553-4840.

		710	710SS	710F	710FSS	710MO	710FMO	711NC	711
Normally Open									✓
Normally Closed		✓	✓	✓	✓	✓	✓	✓	
Thread Size	3/4"	✓	✓			✓		✓	✓
	1"	✓	✓			✓		✓	✓
	1 1/2"	✓	✓			✓		✓	✓
	2"	✓	✓			✓		✓	✓
	3"	✓	✓						✓
Flange Size	1 1/2"			✓	✓				
	2"			✓	✓		✓		
	3"			✓	✓				
Body Construction	Brass/bronze	✓		✓		✓	✓	✓	✓
	Stainless steel		✓		✓				
Hung piston		✓	✓	✓	✓	✓	✓		
Pilot operated								✓	✓
Manual override						✓	✓		
Explosion-proof coil		✓	✓	✓	✓	✓	✓	✓	✓
Zero differential		✓	✓	✓	✓	✓	✓		
Pressure differential 7.5 PSI								✓	✓
Thermal relief feature		✓	✓	✓	✓	✓	✓		

The following coils are available for solenoids ranging in size from 3/4" to 3":

- 120/60 Volt AC
- 208/60 Volt AC
- 220/60 Volt AC
- 240/60 Volt AC
- 480/60 Volt AC
- 220/50 Volt AC
- 240/50 Volt AC

The following coils are available for solenoids ranging in size from 3/4" to 2":

- 12 Volt DC
- 24 Volt DC
- 48 Volt DC



Solenoid Valves

for anti-siphon protection

710
NORMALLY CLOSED



710F
FLANGED

Normally closed solenoid valves are used to help prevent the accidental siphoning of a product from a tank in the event of a leak downstream below the liquid level. They are generally installed on the dispensing side of a fuel system pipeline. The valve opens upon the receipt of an electronic signal such as when a dispenser or pump is switched to the 'on' position.

- Zero pressure differential
- Explosion proof coil
- Hung piston design
- Expansion relief

- Install in a horizontal pipeline in the upright vertical position
- Continuous duty Class H standard coil operates at 120 volts
- Enclosure is watertight and rated for hazardous locations—NEMA 3, 4X, 7 and 9; groups C and D
- Several optional coil voltages available
- Recommended for use with liquids having a maximum viscosity of 60 centistokes
- A strainer with a 100 mesh screen is recommended at the valve inlet
- **710F** has flanged body connections
- **710MO** has manual override feature. Available in sizes ranging from ¾" to 2" for operation during a power outage
- UL Certified (Class I, Division 1, Groups C and D; Class II, Division 1, Groups E, F and G; Class III)
- cULus Listed

Item Number	Size (NPT)	Seal Material	Orifice Size (Inches)	CV	Operating Pressure Differential Max. (P.S.I.)		Fluid Temp. (Max) (Deg. F.)	Power Consumption (Watt)	Ship Weight (lbs)
					Min.	Max			
710-0075 1V	.75"	FKM	.75	7	0	105	302	30	11.0
710-0100 1V	1"	FKM	1.0	12	0	105	302	30	13.0
710-0150 1V	1.5"	FKM	1.25	17	0	105	302	30	16.0
710-0200 1V	2"	FKM	1.50	27	0	105	302	30	21.0
710-0300 1V	3"	FKM	3.0	94	0	45	302	48	44.0
710F-0150 1V	1.5"	FKM	1.25	17	0	105	302	30	25.0
710F-0200 1V	2"	FKM	1.5	27	0	105	302	30	29.0
710F-0300 1V	3"	FKM	3.0	91	0	45	302	48	58.0
710FMO0200 1V	2"	FKM	1.5	27	0	105	302	30	29.0
710MO-0075 1V	.75"	FKM	.75	7	0	105	302	30	12.0
710MO-0100 1V	1"	FKM	1.0	12	0	105	302	30	14.0
710MO-0150 1V	1.5"	FKM	1.25	17	0	105	302	30	17.0
710MO-0200 1V	2"	FKM	1.5	27	0	105	302	30	22.0



710SS
STAINLESS STEEL

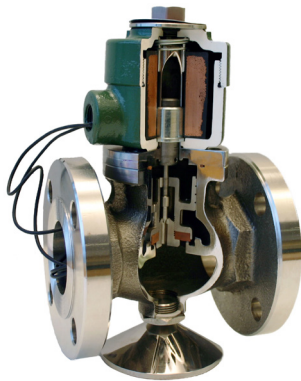

710FSS
CUTAWAY

- Normally closed
- Install in a horizontal pipeline in the upright vertical position
- Integral thermal relief allows the valve to relieve expansion pressure in the opposite direction of flow
- Continuous duty Class H standard coil operates at 120 volts
- Several optional coil voltages available
- Enclosure is watertight and rated for hazardous locations—NEMA 3, 4X, 7 and 9; groups C and D
- Recommended for use with liquids having a maximum viscosity of 60 centistokes
- A strainer with a 100 mesh screen is recommended at the valve inlet
- **710FSS** has flanged body connections
- **710FSM** has manual override feature. Available in sizes ranging from 3/4" to 2" for operation during a power outage
- UL Certified (Class I, Division 1, Groups C and D; Class II, Division 1, Groups E, F and G; Class III)
- cULus Listed

- **Zero pressure differential**
- **Hung piston design**
- **Integrated expansion relief**
- **Explosion proof coil**

Item Number	Size (NPT)	Seal Material	Orifice Size (Inches)	CV	Operating Pressure Differential Max. (P.S.I)		Fluid Temp. (Max) (Deg. F.)	Power Consumption (Watt)	Ship Weight (lbs)
					Min.	Max			
710FSS2150 1V	1.5"	PTFE	1.25	17	0	105	302	30	25.0
710FSS2200 1V	2"	PTFE	1.5	27	0	105	356	30	29.0
710FSS0300 1V	3"	PTFE	3.0	91	0	45	302	48	58.0
710FSM2200 1V	2"	PTFE	1.5	27	0	105	356	30	29.0
710SS-2100 1V	1"	PTFE	1.0	12	0	105	356	30	15.0
710SS-2200 1V	2"	PTFE	1.50	26	0	105	356	30	21.0
710SS-0300 1V	3"	PTFE	3.0	93.6	0	45	302	48	44.0



The 711NC solenoid valve is a high flow pilot operated piston valve that is “normally closed.” This general purpose valve is for applications such as pressure systems, machine tools, water processing, and steam applications. The valve opens upon the receipt of an electronic signal such as when a dispenser or pump is switched to the on position.

- 3 PSI pressure differential required to keep the valve open
- Explosion and weather proof coil and housing
- 120V/60HZ standard, several optional coil voltages available
- Must be installed in a horizontal pipeline with the coil in the upright and vertical position
- Recommended for use with liquids having a maximum viscosity of 60 centistokes
- A strainer with a 100 mesh screen is recommended at the valve inlet
- UL Listed; CSA Approved

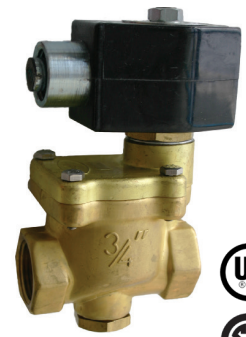

711NC
NORMALLY CLOSED

Item Number	Size (NPT)	Seal Material	Orifice Size (inches)	CV	Operating Pressure Differential MAX. (P.S.I.)		Fluid Temp. (Deg. F)	Power Consumption (Watt)	Weight (lbs.)
					Min.	Max.			
711NC-0075 1V	.75"	FKM	.75	5.9	7.5	225	311	13	2.60
711NC-0100 1V	1"	FKM	1	13	7.5	225	311	13	3.75
711NC-0150 1V	1.5"	FKM	1.5	29	7.5	225	311	13	6.75
711NC-0200 1V	2"	FKM	2	47	7.5	225	311	13	9.47

* Contact Morrison Customer Service for features and options not shown.

for controlled flow

The 711 solenoid valve is a high flow pilot operated piston valve that is “normally open.” This general purpose valve is for applications such as pressure systems, machine tools, water processing, and steam applications. The valve closes upon the receipt of an electronic signal.

- 3 PSI pressure differential required to keep the valve open
- Explosion and weather proof coil and housing
- 120V/60HZ standard; several optional coil voltages available
- Must be installed in a horizontal pipeline with the coil in the upright and vertical position
- Recommended for use with liquids having a maximum viscosity of 60 centistokes
- A strainer with a 100 mesh screen is recommended at the valve inlet
- UL Listed; CSA Approved

711
NORMALLY OPEN



Item Number	Size (NPT)	Orifice Size (inches)	CV	Operating Pressure Differential Max. (P.S.I.)		Fluid Temp. (Deg. F)	Power Consumption (Watt)	Weight (lbs)
				Min.	Max.			
711---0075 1V	.75"	.75	6	7.5	150	220	13	2.60
711---0100 1V	1"	1	13	7.5	150	220	13	3.75
711---0150 1V	1.5"	1.25	30	7.5	150	220	13	6.75
711---0200 1V	2"	1.50	47	7.5	150	220	13	9.47



Flow Charts

710

WATER FLOW VS. PRESSURE DROP

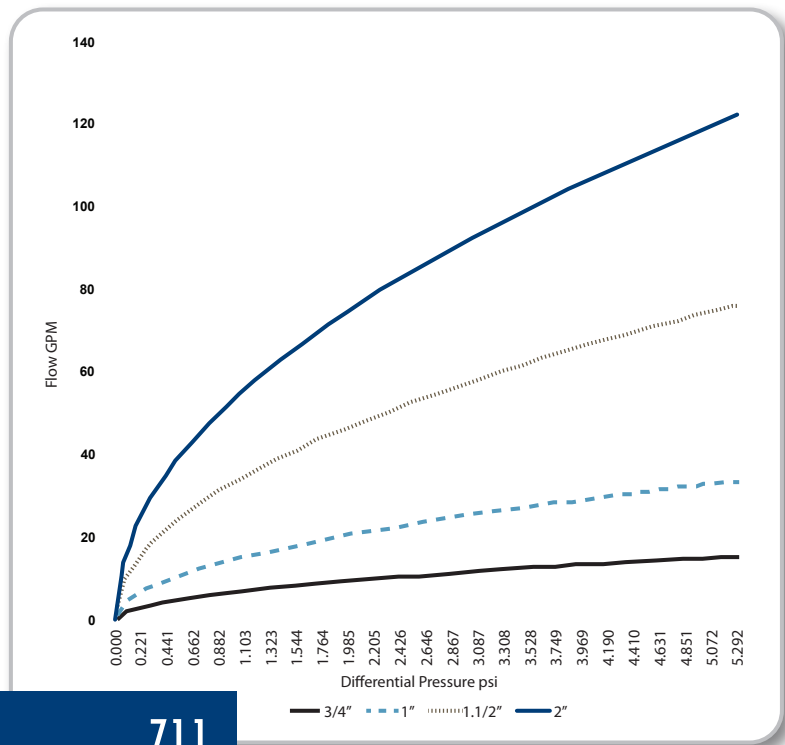
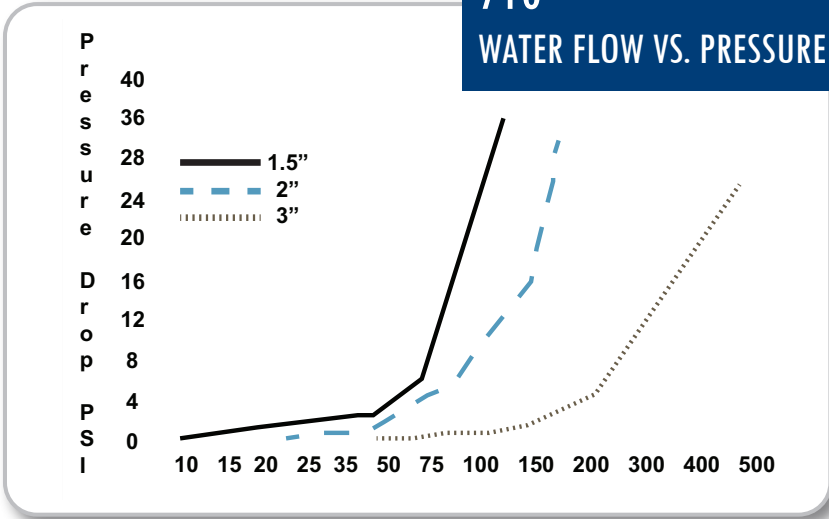

711



Dimensions

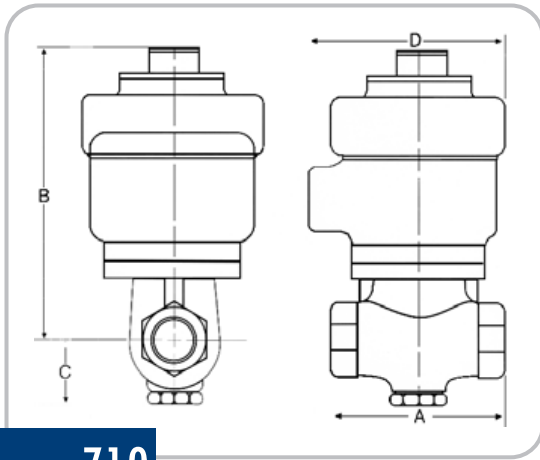

710

Item Number	(Inches)			
	A	B	C	D
710-0075 1V	4.0	5.9	1.5	4.38
710-0100 1V	4.8	6.25	1.75	4.38
710-0150 1V	5.4	6.9	2.0	4.38
710-0200 1V	5.9	7.0	2.25	4.38
710-0300 1V	8.8	9.5	4.5	4.38
710MO-0075 1V	4.0	5.9	1.5	4.38
710MO-0100 1V	4.8	6.25	1.75	4.38
710MO-0150 1V	5.4	6.9	2.0	4.38
710MO-0200 1V	5.9	7.0	2.25	4.38
710SS-2075 1V	4.0	5.9	1.5	4.38
710SS-2100 1V	4.8	6.25	1.75	4.38
710SS-2150 1V	5.4	6.9	2.0	4.38
710SS-2200 1V	5.9	7.0	2.25	4.38
710SS-0300 1V	8.8	9.5	4.5	4.38

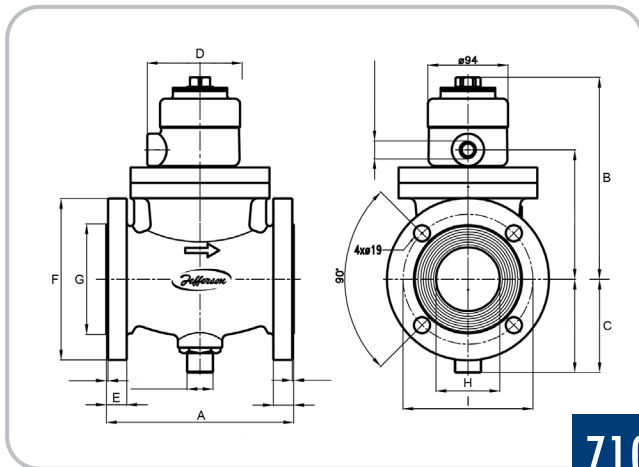

710F

Item Number	(Inches)							
	A	B	C	D	E	F	G	H
710F--0150 1V	6.54	7.67	2.53	4.29	0.72	5.0	2.89	3.86
710F--0200 1V	6.89	7.44	2.99	4.29	0.75	5.98	3.62	4.75
710F--0300 1V	8.66	9.29	4.33	4.29	0.94	7.52	5.0	5.98
710FMO0200 1V	6.89	7.44	2.99	4.29	0.75	5.98	3.62	4.75
710FSS2150 1V	6.54	7.67	2.53	4.29	0.72	5.0	2.89	3.86
710FSS2200 1V	6.89	7.44	2.99	4.29	0.75	5.98	3.62	4.75
710FSS0300 1V	8.66	9.29	4.33	4.29	0.94	7.52	5.0	5.98
710FSM2200 1V	6.89	7.44	2.99	4.29	0.75	5.98	3.62	4.75

711

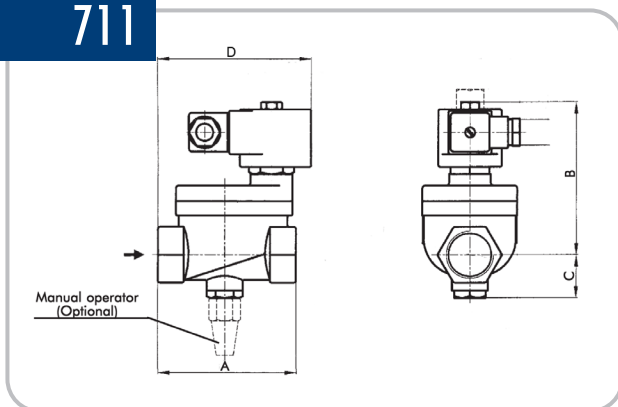

Item Number	(Inches)			
	A	B	C	D
711---0075 1V	2.8	4.45	1.02	3.23
711---0100 1V	3.78	4.57	1.18	3.23
711---0150 1V	4.49	5.11	1.42	3.23
711---0200 1V	5.04	5.18	1.73	3.23
711---0300 1V	8.82	8.71	3.5n	3.23